

# Mist Separator Regulator (SAWM) Micro Mist Separator Regulator (SAWD)

SAWM200~400 Series  
SAWD200~400 Series

- SAWM series are compact type assemblies of a mist separator and a regulator.
- SAWD series are compact type assemblies of a micro mist separator and a regulator.



## How to order

**SAWM** 4 00 - 04 BDG - MeP  
Mist Separator Regulator

**SAWD** 4 00 - 04 BDG - MeP  
Micro Mist Separator Regulator

- Body Size**
  - 2 - 1/4
  - 3 - 3/8
  - 4 - 1/2
- Thread type**
  - Nil - Rc(PT)
  - N - NPT
  - G - G(PF)
- Port Size**

기호	사이즈	몸체 사이즈		
		2	3	4
01	1/8	●		
02	1/4	●	●	
03	3/8		●	
04	1/2			●
- Accessory(Optional)**
  - Nil - None Bracket / Manual Drain / None Gauge
  - B - Bracket
  - D - Auto Drain

Symbol	Description	Body		
		2	3	4
D	One-touch fitting type	●	●	●
Dn	Nipple(PT1/8) type	-	●	●
Df	SAWM, SAWD200 Float type	●	-	-

주) 1. SAWM, SAWD200 are differential pressure type.  
2. SAWM, SAWD300~400 are float type.

G	Round type gauge
Gs	Square embedded type

- Bowl**
  - Nil - Polycarbonate bowl with Nylon guard
  - PcS - Polycarbonate bowl with Steel guard
  - MeP - Metal bowl with pipe type sight glass

## Symbol

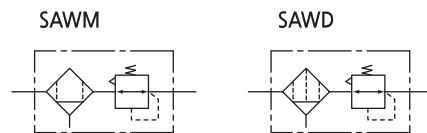

## Specification

Fluid	Compressed Air	
Max. operating pressure	10bar (1.0MPa)	
Max. supply pressure	15bar (1.5MPa)	
Ambient and Media temp.	-5~60℃ (No freezing)	
Regulating range	0.5~8.5bar (0.05~0.85MPa)	
Filtration	SAWM	0.1μm
	SAWD	0.01μm
Bowl material	Poly-carbonate (option: ALDC)	
Bowl Guard Material	Nylon	
Construction	Relief type	

## Precautions

- Set the outlet pressure range for the regulator in a range that is 85% or less of the inlet pressure. If set above 85%, the inlet pressure will be easily effected by fluctuations in the flow rate and inlet pressure, and will become unstable.
- To set the pressure using the knob, turn the knob in the direction that increases pressure and lock the knob after the pressure is set. If this is done in the direction that decreases pressure, the pressure may drop from the original set pressure. Turning the knob clockwise increases the outlet pressure, and turning it counterclockwise reduces the pressure.
- Residual pressure release (outlet pressure release) is not complete by releasing the inlet pressure. To release residual pressure, select a model with a back flow mechanism.
- When auto drain is used, drain piping should be both 4mm or greater in diameter and less than 1m in length. Avoid installing drain piping upwards.
- When auto drain is inoperable, drain manually by pushing the one-touch fitting upward.

# Mist Separator Regulator Micro Mist Separator Regulator

## FLOW CHARACTERISTICS

Inlet pressure 7kg/cm<sup>2</sup>

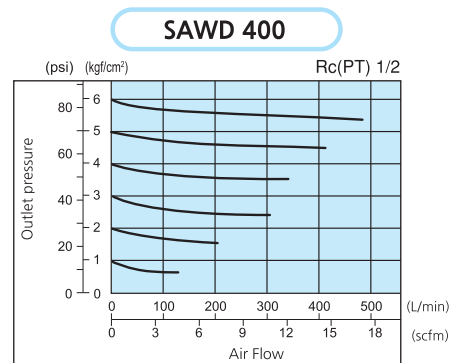
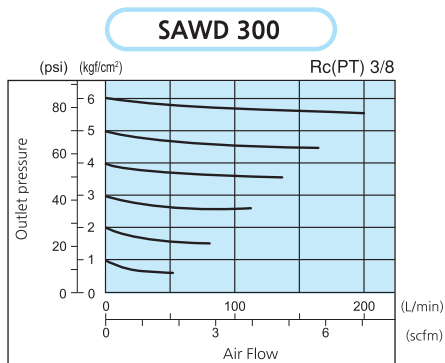
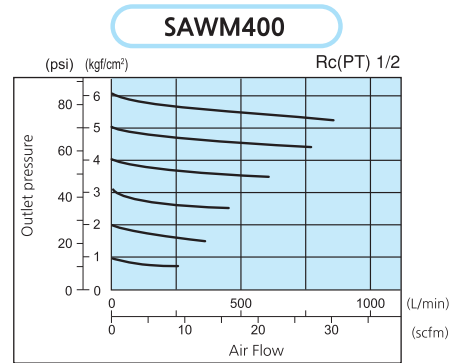
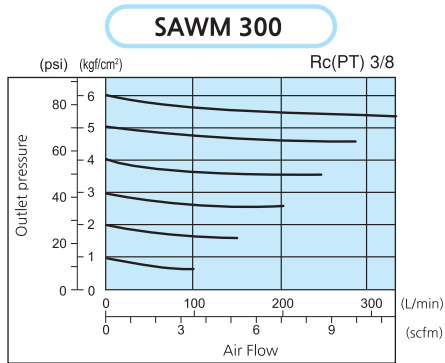

## PRESSURE CHARACTERISTICS

Inlet pressure 7kg/cm<sup>2</sup>, Outlet pressure 2kg/cm<sup>2</sup>, Flow 20L/min(ANR)

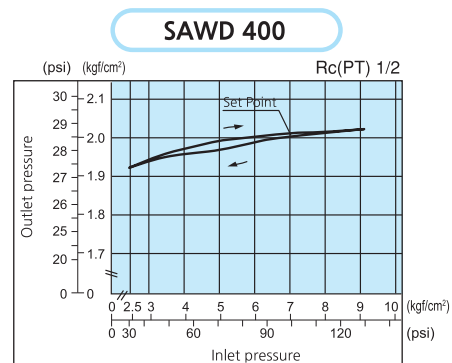
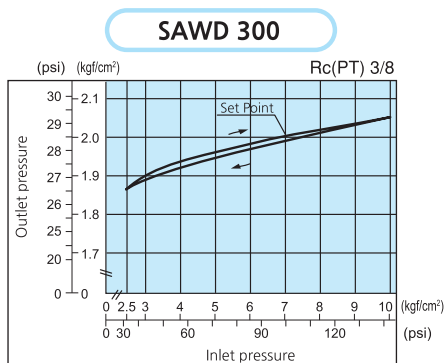
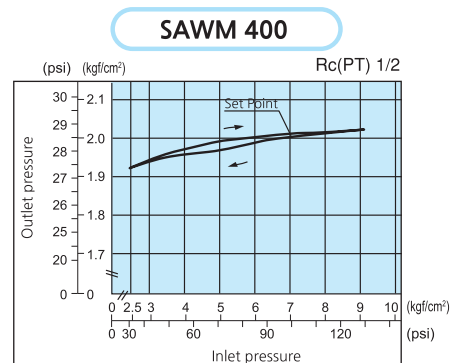
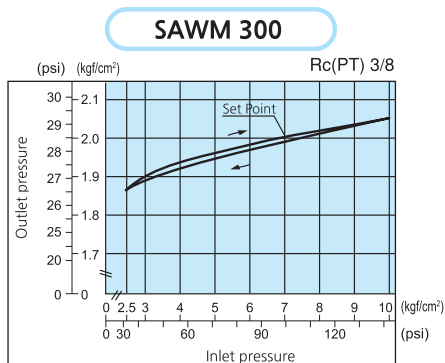

STRUCTURE / PARTS

SAWM 200  
SAWD 200

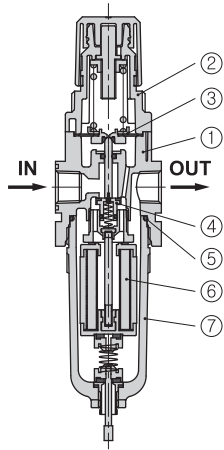

SAWM 300 to 400  
SAWD 300 to 400

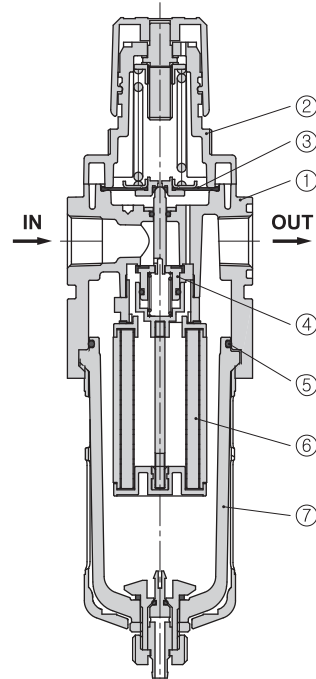

Component Parts

No.	PARTS	MATERIAL
①	Body	ALDC
②	Cover	N66G
③	Diaphragm Ass'y	NBR
④	Check valve Ass'y	Brass, NBR
⑦	Bowl Ass'y <sup>1)</sup>	PC & Nylon

1) Bowl Ass'y for the SAW300 to SAW600 models comes with a bowl guard (steel band material).

Replacement Parts

No.	PARTS	MATERIAL	Part no.					
			SAWM200	SAWD200	SAWM300	SAWD300	SAWM400	SAWD400
⑤	O-ring	NBR	U024		38x2		U137	
⑥	Filter	-	WM200-EL	WD200-EL	WM300-EL	WD300-EL	WM400-EL	WD400-EL

## DIMENSIONS (mm)

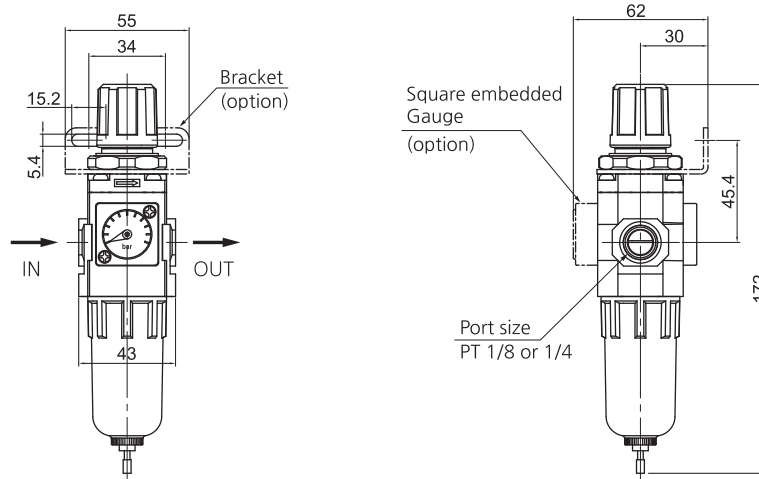

### SAWM(SAWD) 200

- SAWM(SAWD)200-□02□□□-□

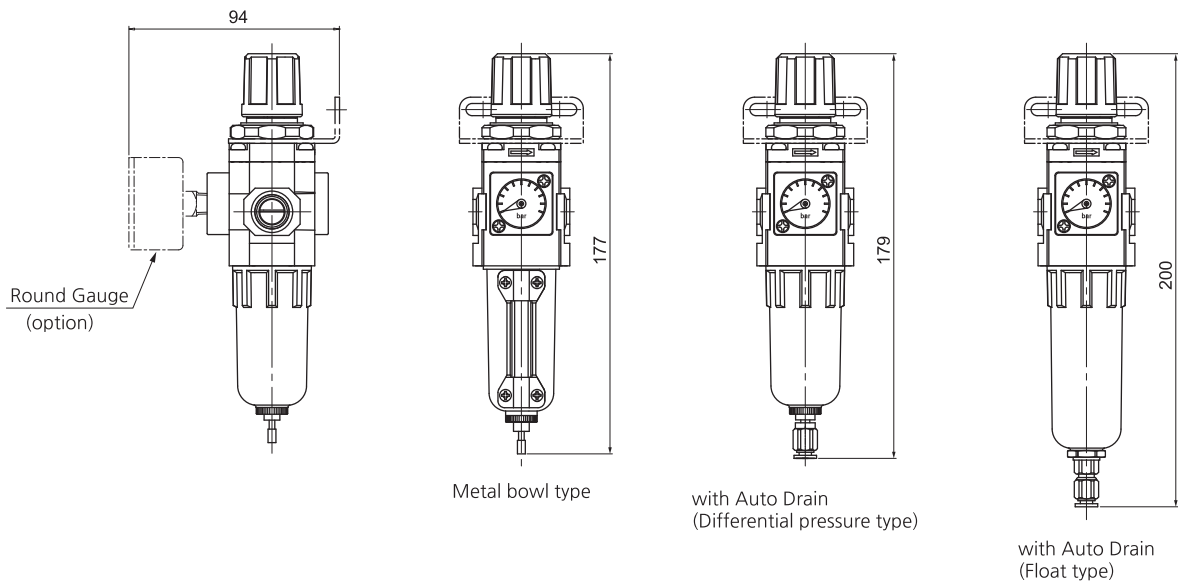

- Dimensions of each model with an option attached

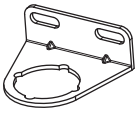

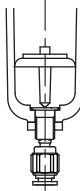
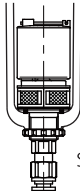
Option	B : Bracket	Gauge		Auto Drain	
		Gs : Square embedded	G : Round type	D : Differential pressure	Df : Float type
Model	 B220	 Gs28	 G40, R1/8		 SAD200

**DIMENSIONS (mm)**

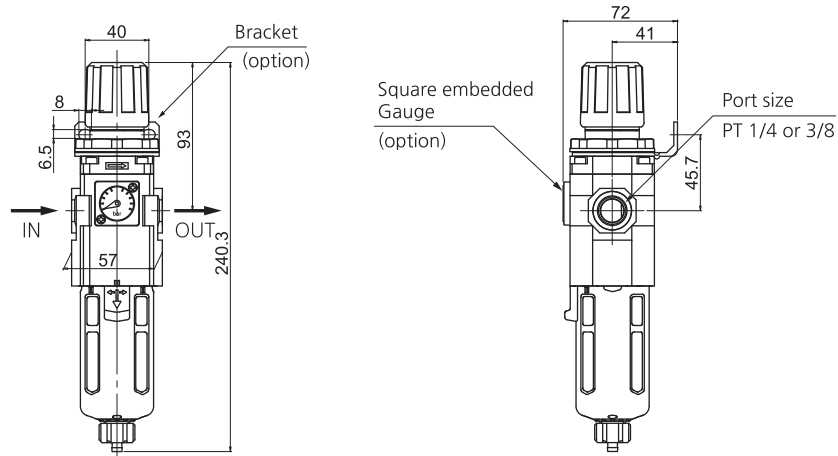

**SAWM(SAWD) 300**

- SAWM(SAWD)300-□03□□□-□

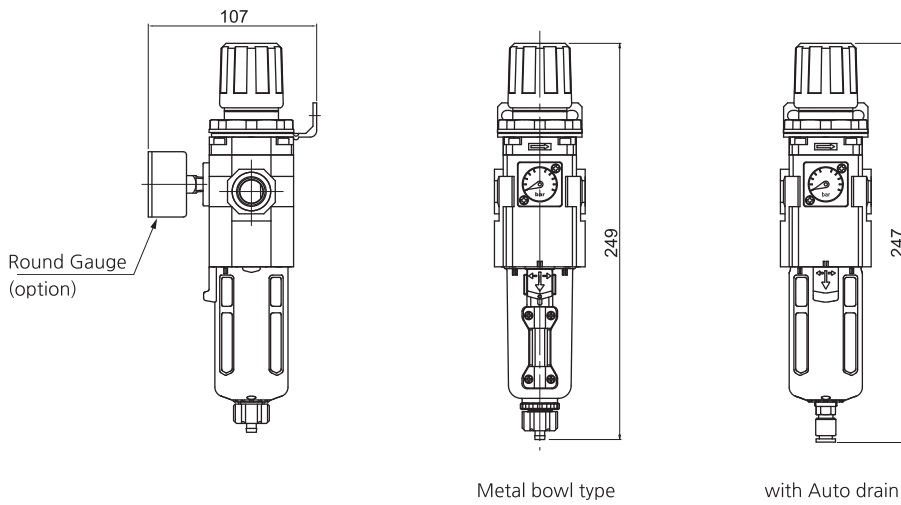

- Dimensions of each model with an option attached

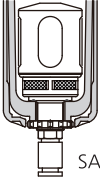

Option	B : Bracket	D : Auto Drain	Gauge	
			G : Round type	Gs : Square embedded type
Model	 B320	 SAD300	 G40, R1/8	 Gs28

## DIMENSIONS (mm)

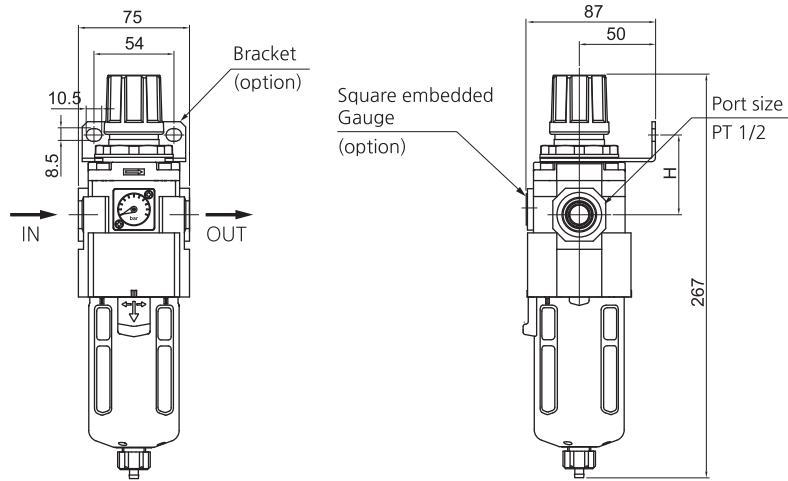

### SAWM(SAWD) 400

- SAWM(SAWD)400-□04□□□-□

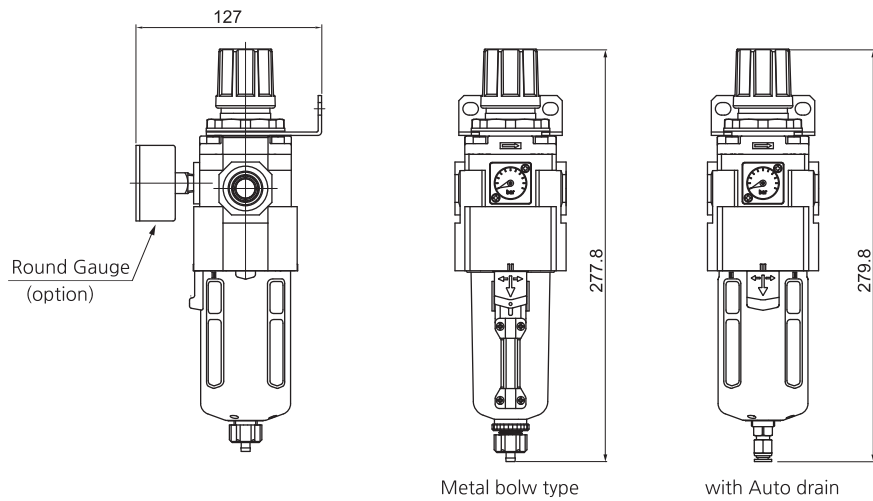

- Dimensions of each model with an option attached

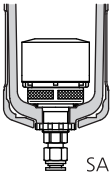

Option	B : Bracket	D : Auto Drain	Gauge	
			G : Round type	Gs :Square embedded type
Model	 B420	 SAD400	 G50, R1/4	 Gs28