

ACL series



ACL-B 140-S125

Features

- Aluminum tube available for Ø125~Ø300. Lighter weight & auto switch type available.
- Steel tube : Ø250~Ø300
- Excellent durability and performance.
- Various mounting styles.

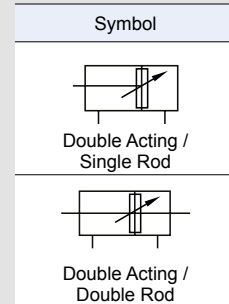

How to Order

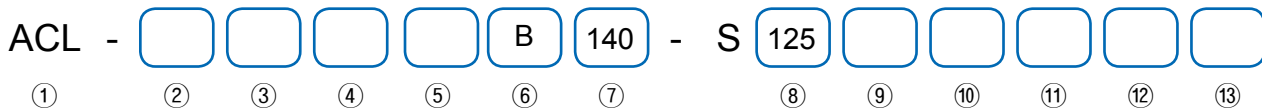

① Series

ACL	Double acting single rod large cylinder
ACLW	Double acting double rod large cylinder

② Lubrication

Nil	Lubricated
N	Non lubricated (Standard)
L	Low hydraulic pressure (≤5kgf/cm ²)
G	Low hydraulic pressure (≤25kgf/cm ²)

③ Magnet

Nil	Without built-in magnet
H	Built-in magnet

④ Tube material

Nil	AL
F	Steel

⑤ Cover material

	Ø125~Ø200	Ø250~Ø300
Nil	AL(Standard)	Steel(Standard)
FC	Steel	-

⑥ Mounting style

B	Standard	CB	Double Clevis
LB	Foot	TC	Center Trunnion
FA	Rod Side Flange	TA	Rod Side Trunnion
FB	Head Side Flange	TB	Head Side Trunnion
CA	Single Clevis		

⑦ Bore size

125	140	150	160
Ø125	Ø140	Ø150	Ø160
180	200	250	300
Ø180	Ø200	Ø250	Ø300

* Refer to page [1]-133, for specifications about custom-made rod ends.

⑧ Cylinder stroke

Bore size	Standard stroke	Max. stroke
Ø125	25, 50, 75, 100, 125, 150, 175, 200, 250, 300, 350, 400, 450, 500	2950
Ø140	25, 50, 75, 100, 125, 150, 175, 200, 250, 300	
Ø150	25, 50, 75, 100, 125, 150, 175, 200, 250, 300, 350, 400, 450, 500	
Ø160	25, 50, 75, 100, 125, 150, 175, 200, 250, 300	
Ø180	25, 50, 75, 100, 125, 150, 175, 200, 250, 300	-
Ø250	50, 100, 150, 200, 250, 300	
Ø300	-	

* Other intermediate strokes available on request.

⑨ Bellows

	Material	Max. ambient temperature
Nil	Without bellows	
J	Nylon Tarpaulin	60 °C
K	Neoprene Cloth	110 °C

⑩ Rod end attachment

Nil	Rod end nut(Standard) : 1pc
I	Single knuckle joint
Y	Double knuckle joint

⑪ Auto switch

Reed A/S	Model	Solid state A/S	Model
A54	D-A54K	F59	D-F59K
A56	D-A56K	F5P	D-F5PK
A64	D-A64K	J59	D-J59K
A90(V)	D-A90(V)K	J51	D-J51K
A93(V)	D-A93(V)K	F9N	D-F9N(V)K
A96(V)	D-A96(V)K	F9P	D-F9P(V)K
		F9B	D-F9B(V)K

* Only for auto switch attached type.

* Refer to Auto Switch Catalogue for more information.

⑫ Number of auto switches

Nil	2 pcs
1	1 pc
N	N pcs (N: 3, 4, 5...)

* Only for auto switch attached type.

⑬ Special Order

Nil	None
TS	Multi-step stroke cylinder (Single rod)
TW	Multi-step stroke cylinder (Double rod)
TD	Tandem cylinder
ASJ	Stroke adjustable type (in forward direction within 25mm)
BSJ	Stroke adjustable type (in forward direction within 50mm)
SV	Heat resistant cylinder (-20 °C~150 °C)
SS	Stainless steel piston rod



Specifications

Type	Lubricated, Non-lubricated	Low hydraulic pressure
Fluid	Air	Turbine Oil VG32
Proof pressure	16kgf/cm ² (1.6MPa)	
Max. operating pressure	9.9kgf/cm ² (0.99MPa)	Low pressure L type:5kgf/cm ² (0.5MPa)
Min. operating pressure	0.8kgf/cm ² (0.08MPa)	1kgf/cm ² (0.1MPa)
Ambient & fluid temperature	5 ~ 60 °C	
Operating piston speed	50 ~ 500mm/sec	0.5 ~ 200mm/sec
Cushion	With cushion	Without cushion
Tolerance of thread	KS class 2	
Tolerance of stroke	~250 ST : ^{+1.0} ₀	251 ~ 1000 ST : ^{+1.4} ₀ 1001 ~ 1500 ST : ^{+1.8} ₀

Accessory

Type		Double acting single rod						
Mounting style		Standard	Foot	Rod side flange	Head side flange	Single clevis	Double clevis	Center trunnion
Standard mounting	Rod end nut	•	•	•	•	•	•	•
	Clevis pin	-	-	-	-	-	•	-
Option	Single knuckle joint	•	•	•	•	•	•	•
	Double knuckle joint	•	•	•	•	•	•	•
	Bellows	•	•	•	•	•	•	•

* For double clevis and double knuckle joint, pin and snap ring are included.

Mounting Style

Mounting style	Bore size	Ø125	Ø140	Ø150	Ø160	Ø180	Ø200	Ø250	Ø300
	Foot		LB125	LB140	LB150	LB160	LB180	LB200	LB250
Flange		FA/ FB125	FA/ FB140	FA/ FB150	FA/ FB160	FA/ FB180	FA/ FB200	FA/ FB250	FA/ FB300
Single clevis (with pin)		CA125	CA140	CA150	CA160	CA180	CA200	CA250	CA300
Double clevis (with pin)		CB125	CB140	CB150	CB160	CB180	CB200	CB250	CB300

* For foot type mounting, 2 pieces in one set.

Rod End Attachment

Rod end attachment	Bore size	Ø125	Ø140	Ø150, Ø160	Ø180	Ø200	Ø250	Ø300
	Single knuckle joint		I125	I140	I150/160	I180	I200	I250
Double knuckle joint		Y125	Y140	Y150/160	Y180	Y200	Y250	Y300

Pneumatic
Cylinder

Reference
Data

AJP

KGUA

ACP

ACD

ACS2

ACS3

ACS4

ACS5

ACR

ACM

ACL

ACX

KLC

KLCS

AF, ADF

AFG

FM, FMD

Custom-
Made
Rod Ends

Custom-
Made
Tie Rods

KBP

CCTS

Mass

Unit: kg

Bore size (mm)		Aluminium tube							
		Double acting single rod				Double acting double rod			
		Ø125	Ø140	Ø150	Ø160	Ø125	Ø140	Ø150	Ø160
Basic mass	Standard	5.38	6.76	8.82	11.78	5.98	7.38	9.49	12.67
	Foot	7.18	8.92	11.58	14.70	7.78	9.54	12.25	15.59
	Flange	8.32	12.40	14.96	18.80	8.92	13.02	15.63	19.69
	Single clevis	8.60	11.42	14.40	17.76	-	-	-	-
	Double clevis (with pin)	8.88	11.74	15.10	18.28	-	-	-	-
	Trunnion	9.51	12.49	15.77	19.18	10.11	13.11	16.44	20.07
Additional mass for each 100mm stroke		1.68	1.68	2.16	2.20	2.37	2.44	3.05	3.11
Accessory	Single knuckle joint	1.04	1.26	1.63	1.63	-	-	-	-
	Double knuckle joint (with pin)	1.37	1.88	2.43	2.43	-	-	-	-
	Rod end nut	0.16	0.16	0.26	0.26	-	-	-	-

Unit: kg

Bore size (mm)		Steel tube													
		Double acting single rod						Double acting double rod							
		Ø125	Ø140	Ø160	Ø180	Ø200	Ø250	Ø300	Ø125	Ø140	Ø160	Ø180	Ø200	Ø250	Ø300
Basic mass	Standard	15.20	18.38	25.24	34.16	42.66	79.78	115.94	16.85	20.03	27.12	36.90	45.79	85.36	122.39
	Foot	16.83	20.90	28.04	38.36	47.54	89.28	133.22	18.48	22.55	29.92	41.10	50.67	94.86	139.67
	Rod side flange	17.88	23.38	31.63	43.99	54.57	101.62	146.14	-	-	-	-	-	-	-
	Head side flange	17.88	23.38	31.63	43.99	54.57	101.62	146.14	-	-	-	-	-	-	-
	Single clevis	18.27	22.67	30.73	42.55	52.56	98.17	149.22	-	-	-	-	-	-	-
	Double clevis (with pin)	18.73	23.42	34.58	44.23	54.59	101.36	154.96	-	-	-	-	-	-	-
	Trunnion	19.33	24.11	32.64	44.78	56.65	107.62	156.37	20.98	25.76	34.52	47.52	59.78	113.20	162.82
Additional mass for each 100mm stroke		2.66	3.01	3.58	4.95	5.75	9.08	12.15	3.46	3.81	4.57	6.20	7.29	11.30	15.17
Accessory	Single knuckle joint	0.91	1.16	1.56	3.07	2.90	5.38	10.82	-	-	-	-	-	-	-
	Double knuckle joint (with pin)	1.37	1.81	2.48	4.74	4.59	9.22	17.17	-	-	-	-	-	-	-
	Rod end nut	0.16	0.16	0.2	0.32	0.85	1.26	1.43	-	-	-	-	-	-	-

Calculation:

- Double acting single rod (Aluminium tube)
Ex) ACL-LB160-S500
Basic mass: 14.70(FootØ160) / Additional mass: 2.20/100 / Cylinder stroke: 500mm
 $14.70 + 2.20/100 \times 500 = 25.70\text{kg}$
- Double acting double rod (Aluminium tube)
Ex) ACLW-LB125-S500
Basic mass: 7.78(FootØ125) / Additional mass: 2.37/100 / Cylinder stroke: 500mm
 $7.78 + 2.37/100 \times 500 = 19.63\text{kg}$

Structure

Standard (Lubricated type) (Ø125, Ø140, Ø150, Ø160)

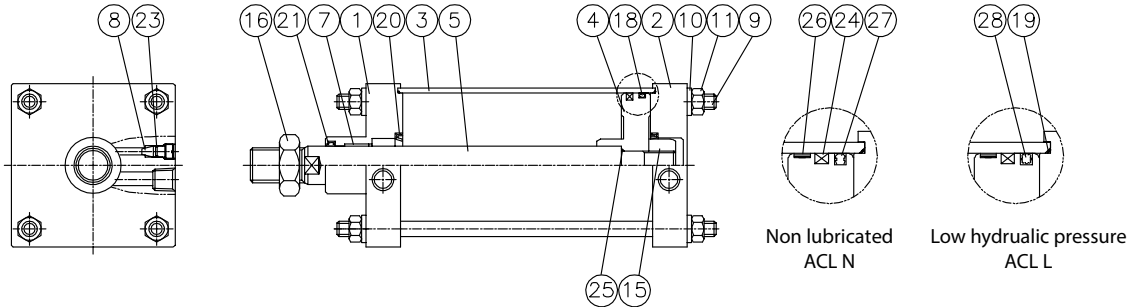

Standard (Lubricated type) (Ø180, Ø200, Ø250, Ø300)

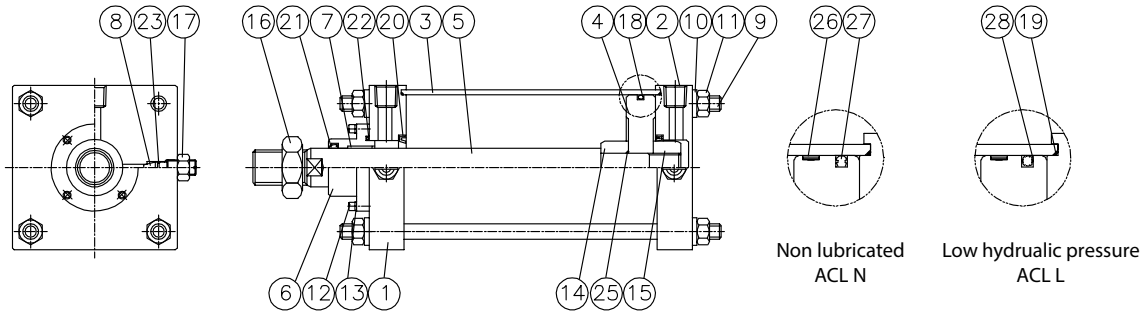

No.	Parts	Material	Remark
1	Rod Cover	AL Alloy	Ø125~Ø160
		Rolled Steel Sheet	Ø180~Ø300
2	Head Cover	AL Alloy	Ø125~Ø160
		Rolled Steel Sheet	Ø180~Ø300
3	Tube Ø125~Ø160 Ø180~Ø300	AL Alloy	Hard Anodized Aluminium
		Carbon Steel Tube	Hard Chromium Plating
4	Piston	AL Alloy	Ø125~Ø160
		Cast Iron	Ø180~Ø300
5	Rod	Carbon Steel	Hard Chromium Plating
6	Secondary Block (Ø180~Ø300)	Cast Iron	Black Oxide Coating
7	Bush	DU Bush	-
8	Cushion Needle	Brass	-
9	Tie Rod	Carbon Steel	Zinc Plating
10	Spring Washer	Hard Steel Wire	-
11	Tie Rod Nut	Carbon Steel	Zinc Plating
12	Secondary Block	Grey Cast Iron	-
13	Spring Bolt of Secondary Block	Chrome-Molybdenum Steel	-
14	Cushion Ring (Rod Side)	Carbon Steel	-
15	Cushion Ring (Head Side)	Carbon Steel	-
16	Rod End Nut	Rolled Steel	-
17	Cushion Needle (Ø180~Ø300)	Rolled Steel	-

Type	No.	Parts	Material	Bore size							
				125	140	150	160	180	200	250	300
Lubrication	18	Piston Packing	NBR	AP115	AP130	AP140	AP150	AP165	AP185	AP235	AP285
	19	Tube O-Ring		Ø125 ×W2.0	Ø140 ×W2.0	Ø150 ×W2.0	Ø160 ×W2.0	Ø180 ×W2.0	Ø200 ×W2.0	Ø250 ×W2.0	Ø300 ×W2.0
	20	Cushion Packing		PCS50	PCS50	PCS55	PCS55	PCS60	PCS60	PCS75	PCS80
	21	Rod Packing		DRP35	DRP35	DRP40	DRP40	DRP45	DRP50	DRP60	DRP70
	22	Bush O-Ring		-	-	-	-	AP63	AP67	AP80	AP85
	23	Cushion Needle O-Ring		S10	S10	S10	S10	S10	S10	S10	S10
	24	Magnet		Ø125	Ø140	Ø150	Ø160	-	-	-	-
Note1) Non Lubricated	26	Wearing	RESIN	HWR8	HWR8	HWR8	HWR8	HWR8	HWR8	HWR8	HWR8
				27	Piston Packing	NBR	OPA 125	OPA 140	OPA 150	OPA 160	OPA 180
	28	Piston Packing	NBR	DXP 125	DXP 140	DXP 150	DXP 160	-	-	-	-

※ Note 1) For non lubricated type, wearing 26 and piston packing 27 are applied, while other packing are the same as that of lubricated type.
 ※ Note 2) Piston packing for low pressure type cylinder is piston packing 28, while other packing are the same as that of lubricated type.

Dimensions-Standard (B)

Ø125, Ø140, Ø150, Ø160, Ø180, Ø200

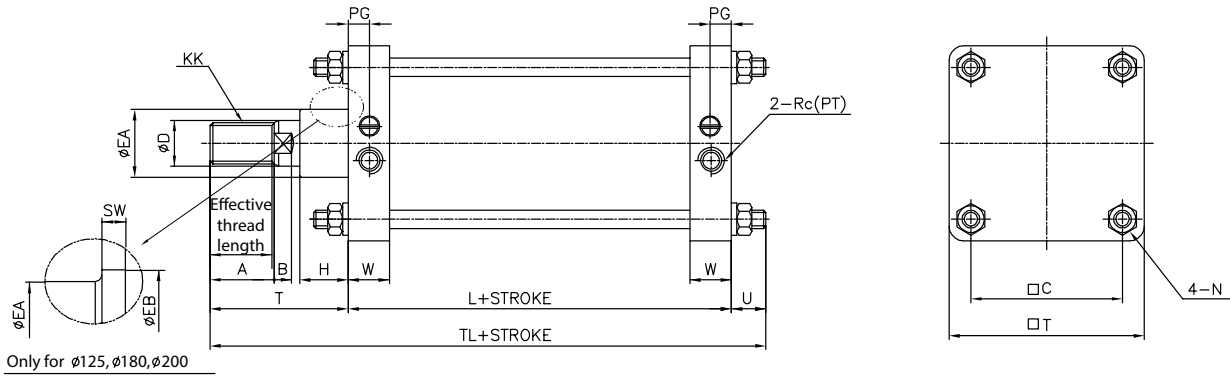

Ø250, Ø300

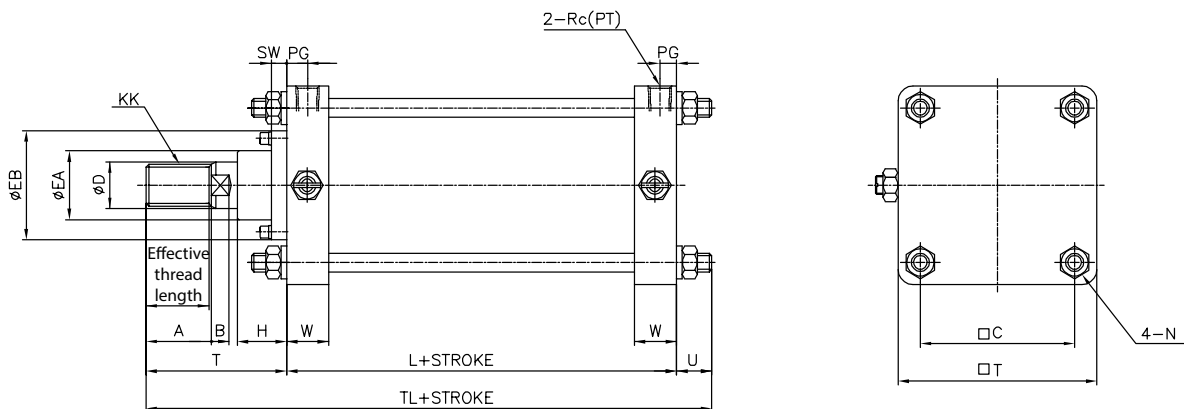

Unit : mm

Bore size	Effective thread length	A	B	□C	ØD	ØEA	ØEB	H	KK	L	N	PG	Rc(PT)	SW
Ø125	47	50	15	115	35	59	70	42	M30X1.5	98	M14X1.5	16	1/2	-
Ø140	47	50	15	128	35	59	-	42	M30X1.5	98	M14X1.5	16	1/2	-
Ø150	53	56	17	132	40	59	-	43	M36X1.5	106	M16X1.5	17.5	3/4	-
Ø160	53	56	17	144	40	59	-	43	M36X1.5	106	M16X1.5	17	3/4	-
Ø180	60	63	20	162	45	70	85	48	M40X1.5	111	M18X1.5	18	3/4	17
Ø200	60	63	20	182	50	74	85	48	M45X1.5	111	M20X1.5	18	3/4	17
Ø250	67	71	25	225	60	96	140	60	M56X2.0	141	M24X1.5	22	1	20
Ø300	76	80	30	270	70	96	140	60	M64X2.0	146	M30X1.5	22	1	20

Bore size	□T	T	TL	U	W
Ø125	145	110	235	(21)	32
Ø140	161	110	235	(21)	32
Ø150	170	120	256.5	(23)	36
Ø160	184	120	256.5	(23)	36
Ø180	204	135	281	(26)	39
Ø200	226	135	281	(30)	38
Ø250	277	160	342.5	(34)	49
Ø300	330	175	372.5	(41.5)	49

Dimensions-Foot (LB)

Ø125, Ø140, Ø150, Ø160, Ø180, Ø200

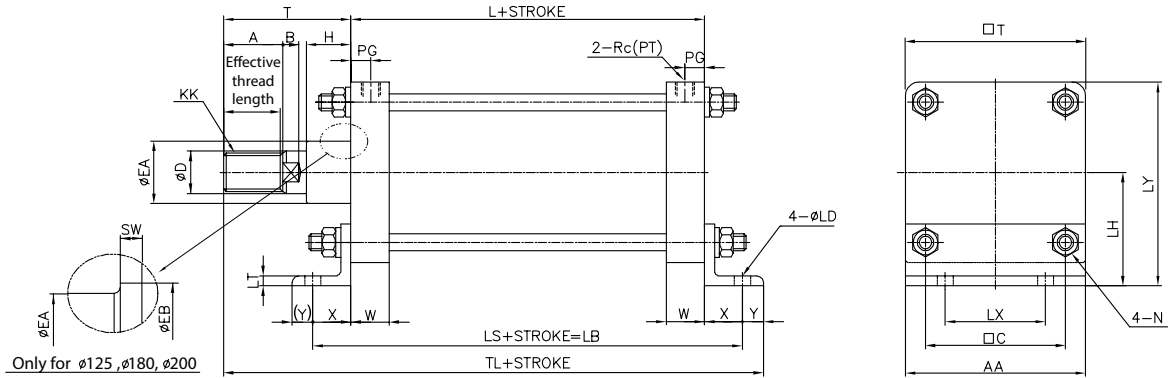

Only for Ø125, Ø180, Ø200

Ø250, Ø300

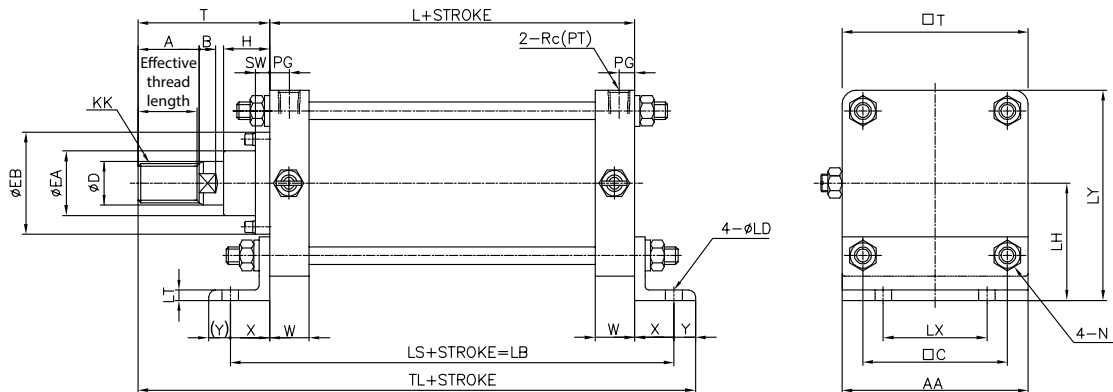

Unit : mm

Bore size	Effective thread length	A	AA	B	□C	ØD	ØEA	ØEB	H	KK	L	ØLD	LH	LS	LT
Ø125	47	50	145	15	115	35	59	70	42	M30X1.5	98	19	85	188	8
Ø140	47	50	161	15	128	35	59	-	42	M30X1.5	98	19	100	188	9
Ø150	53	56	170	17	132	40	59	-	43	M36X1.5	106	19	105	206	9
Ø160	53	56	184	17	144	40	59	-	43	M36X1.5	106	19	106	206	9
Ø180	60	63	204	20	162	45	70	85	48	M40X1.5	111	24	125	231	10
Ø200	60	63	226	20	182	50	74	85	48	M45X1.5	111	24	132	231	10
Ø250	67	71	277	25	225	60	96	140	60	M56X2.0	141	29	160	301	12
Ø300	76	80	330	30	270	70	96	140	60	M64X2.0	146	33	200	326	15

Bore size	LX	LY	N	PG	Rc(PT)	SW	T	□T	TL	W	X	Y
Ø125	100	157.5	M14X1.5	16	1/2	10	110	145	273	32	45	(20)
Ø140	112	180.5	M14X1.5	16	1/2	-	110	161	273	32	45	(20)
Ø150	118	190	M16X1.5	17.5	3/4	-	120	170	301	36	50	(25)
Ø160	118	197	M16X1.5	17	3/4	-	120	184	301	36	50	(25)
Ø180	132	227	M18X1.5	18	3/4	17	135	204	336	39	60	(30)
Ø200	150	245	M20X1.5	18	3/4	8	135	226	336	38	60	(30)
Ø250	180	298.5	M24X1.5	22	1	20	160	277	421	49	80	(40)
Ø300	212	365	M30X1.5	22	1	20	175	330	451	49	90	(40)

Dimensions-Rod Side Flange (FA)

Ø125, Ø140, Ø150, Ø160, Ø180, Ø200

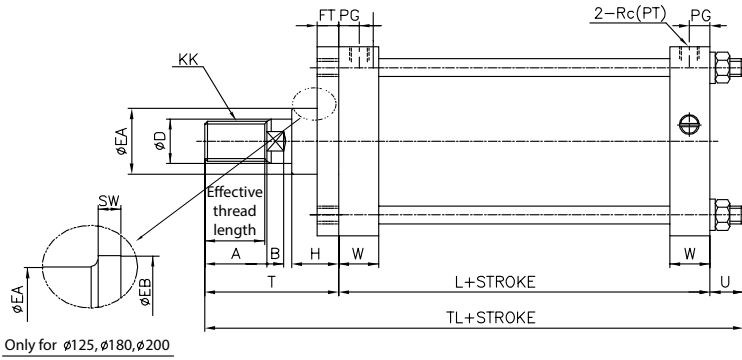

Only for Ø125, Ø180, Ø200

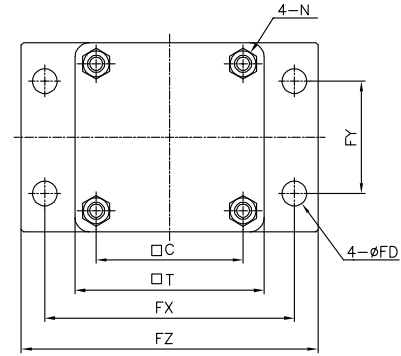

Ø250, Ø300

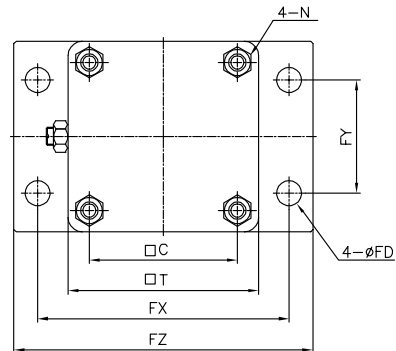
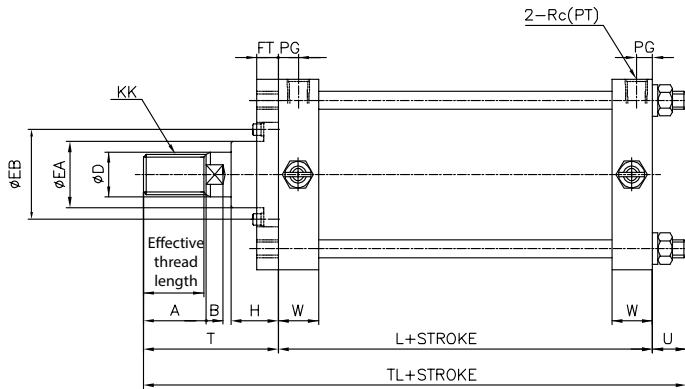

Unit : mm

Bore size	Effective thread length	A	B	□C	ØD	ØEA	ØEB	ØFD	FT	FX	FY	FZ	H	KK
Ø125	47	50	15	115	35	59	70	19	14	190	100	230	42	M30X1.5
Ø140	47	50	15	128	35	59	-	19	20	212	112	255	42	M30X1.5
Ø150	53	56	17	132	40	59	-	19	20	228	115	265	43	M36X1.5
Ø160	53	56	17	144	40	59	-	19	20	236	118	275	43	M36X1.5
Ø180	60	63	20	162	45	70	85	24	25	265	132	320	48	M40X1.5
Ø200	60	63	20	182	50	74	85	24	25	280	150	335	48	M45X1.5
Ø250	67	71	25	225	60	96	140	29	30	355	180	420	60	M56X2.0
Ø300	76	80	30	270	70	96	140	33	30	400	212	475	60	M64X2.0

Bore size	L	N	PG	Rc(PT)	SW	□T	T	TL	U	W
Ø125	98	M14X1.5	16	1/2	10	145	110	232	(25)	32
Ø140	98	M14X1.5	16	1/2	-	161	110	232	(25)	32
Ø150	106	M16X1.5	17.5	3/4	-	170	120	252	(27)	36
Ø160	106	M16X1.5	17	3/4	-	184	120	252	(27)	36
Ø180	111	M18X1.5	18	3/4	17	204	135	277	(30)	39
Ø200	111	M20X1.5	18	3/4	8	226	135	277	(35)	38
Ø250	141	M24X1.5	22	1	20	277	160	336	(40)	49
Ø300	146	M30X1.5	22	1	20	330	175	369	(49)	49

Dimensions-Head Side Flange (FB)

Ø125, Ø140, Ø150, Ø160, Ø180, Ø200

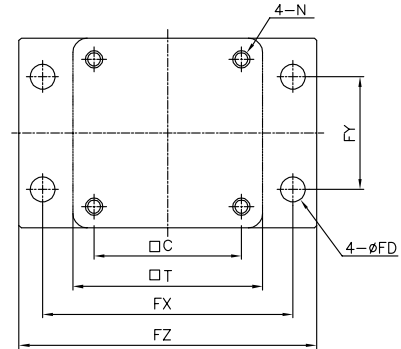
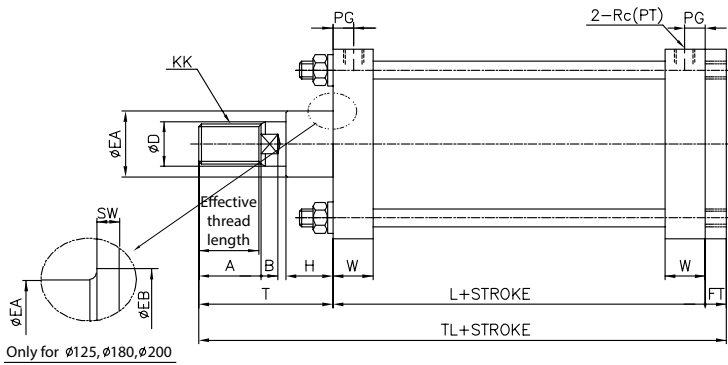

Ø250, Ø300

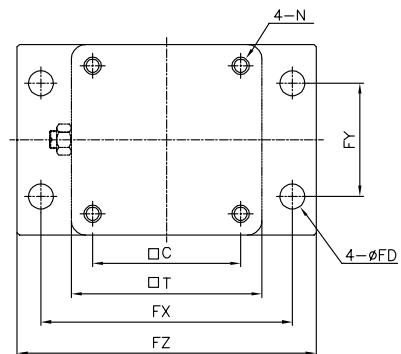
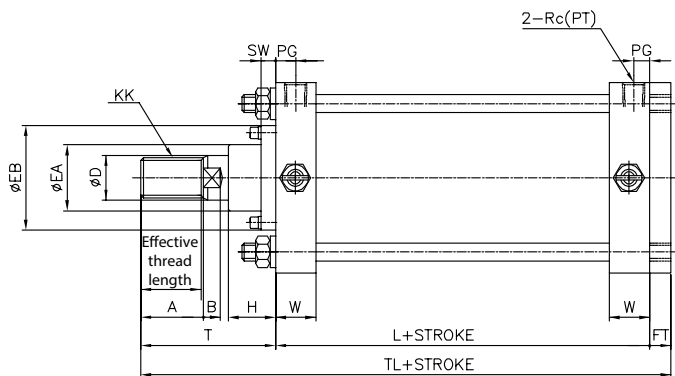

Unit : mm

Bore size	Effective thread length	A	B	□C	ØD	ØEA	ØEB	ØFD	FT	FX	FY	FZ	H	KK
Ø125	47	50	15	115	35	59	70	19	14	190	100	230	42	M30X1.5
Ø140	47	50	15	128	35	59	-	19	20	212	112	255	42	M30X1.5
Ø150	53	56	17	132	40	59	-	19	20	228	115	265	43	M36X1.5
Ø160	53	56	17	144	40	59	-	19	20	236	118	275	43	M36X1.5
Ø180	60	63	20	162	45	70	85	24	25	265	132	320	48	M40X1.5
Ø200	60	63	20	182	50	74	85	24	25	280	150	335	48	M45X1.5
Ø250	67	71	25	225	60	96	140	29	30	355	180	420	60	M56X2.0
Ø300	76	80	30	270	70	96	140	33	30	400	212	475	60	M64X2.0

Bore size	L	N	PG	Rc(PT)	SW	□T	T	TL	W
Ø125	98	M14X1.5	16	1/2	10	145	110	222	32
Ø140	98	M14X1.5	16	1/2	-	161	110	228	32
Ø150	106	M16X1.5	17.5	3/4	-	170	120	246	36
Ø160	106	M16X1.5	17	3/4	-	184	120	246	36
Ø180	111	M18X1.5	18	3/4	17	204	135	271	39
Ø200	111	M20X1.5	18	3/4	8	226	135	271	38
Ø250	141	M24X1.5	22	1	20	277	160	331	49
Ø300	146	M30X1.5	22	1	20	330	175	351	49

Pneumatic Cylinder

Reference Data

AJP

KGUA

ACP

ACD

ACS2

ACS3

ACS4

ACS5

ACR

ACM

ACL

ACX

KLC

KLCS

AF, ADF

AFG

FM, FMD

Custom-Made Rod Ends

Custom-Made Tie Rods

KBP

CCTS

Dimensions-Single Clevis (CA)

Ø125, Ø140, Ø150, Ø160, Ø180, Ø200

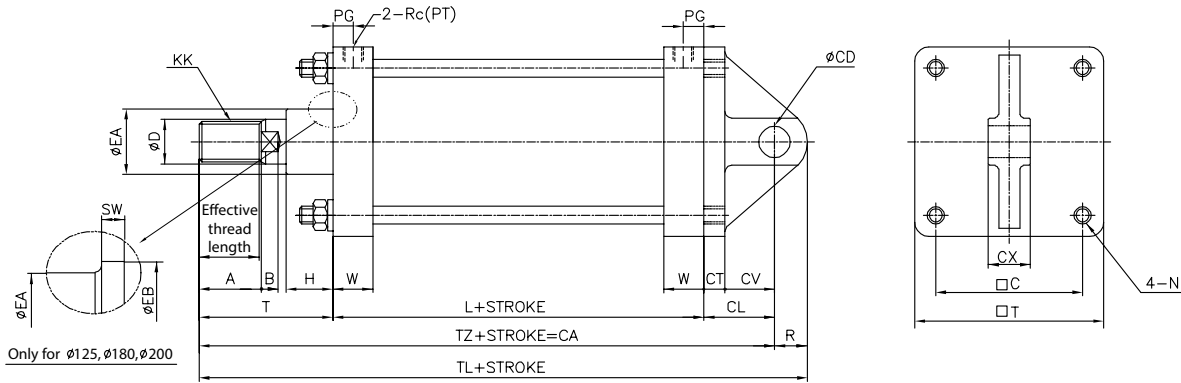

Ø250, Ø300

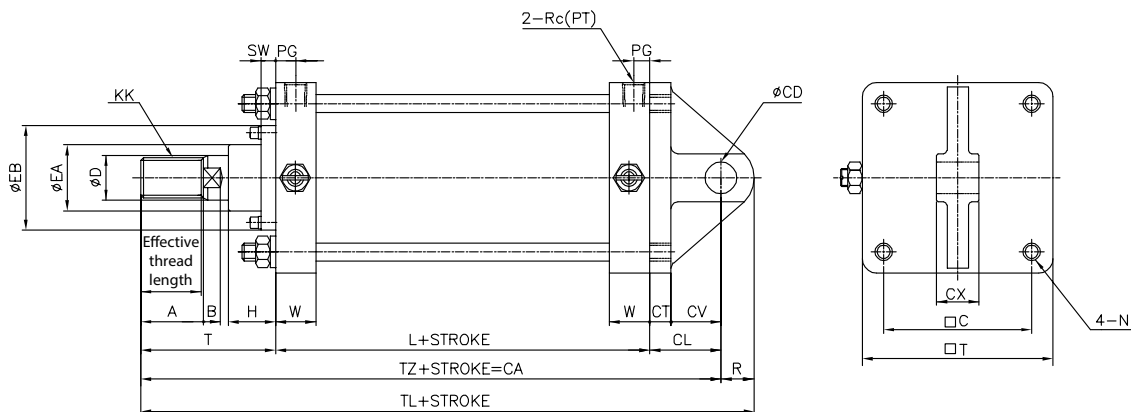

Unit : mm

Bore size	Effective thread length	A	B	□C	ØCD	CL	CT	CV	CX	ØD	ØEA	ØEB	H
Ø125	47	50	15	115	25 ^{+0.10} ₀	65	17	48	32 ^{-0.1} _{-0.3}	35	59	70	42
Ø140	47	50	15	128	28 ^{+0.10} ₀	75	17	58	36 ^{-0.1} _{-0.3}	35	59	-	42
Ø150	53	56	17	132	32 ^{+0.10} ₀	80	20	60	40 ^{-0.1} _{-0.3}	40	59	-	43
Ø160	53	56	17	144	32 ^{+0.10} ₀	80	20	60	40 ^{-0.1} _{-0.3}	40	59	-	43
Ø180	60	63	20	162	40 ^{+0.10} ₀	90	23	67	50 ^{-0.1} _{-0.3}	45	70	85	48
Ø200	60	63	20	182	40 ^{+0.10} ₀	90	25	65	50 ^{-0.1} _{-0.3}	50	74	85	48
Ø250	67	71	25	225	50 ^{+0.10} ₀	110	30	80	63 ^{-0.1} _{-0.3}	60	96	140	60
Ø300	76	80	30	270	63 ^{+0.12} ₀	130	37	93	80 ^{-0.1} _{-0.3}	70	96	140	60

Bore size	KK	L	N	PG	Rc(PT)	R	SW	□T	T	TL	TZ	W
Ø125	M30X1.5	98	M14X1.5	16	1/2	29	10	145	110	302	273	32
Ø140	M30X1.5	98	M14X1.5	16	1/2	32	-	161	110	315	283	32
Ø150	M36X1.5	106	M16X1.5	17.5	3/4	36	-	170	120	342	306	36
Ø160	M36X1.5	106	M16X1.5	17	3/4	36	-	184	120	342	306	36
Ø180	M40X1.5	111	M18X1.5	18	3/4	44	17	204	135	380	336	39
Ø200	M45X1.5	111	M20X1.5	18	3/4	44	8	226	135	380	336	38
Ø250	M56X2.0	141	M24X1.5	22	1	55	20	277	160	466	411	49
Ø300	M64X2.0	146	M30X1.5	22	1	68	20	330	175	519	451	49



Dimensions-Double Clevis (CB)

Ø125, Ø140, Ø150, Ø160, Ø180, Ø200

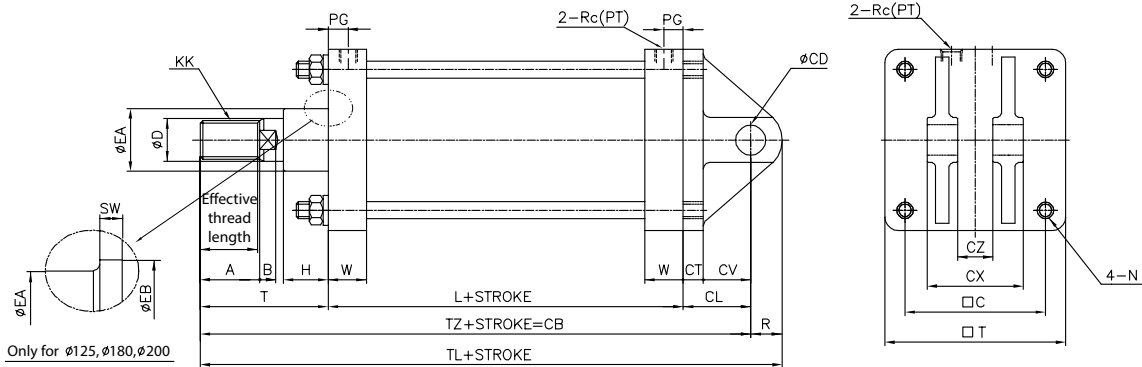

Only for Ø125, Ø180, Ø200

Ø250, Ø300

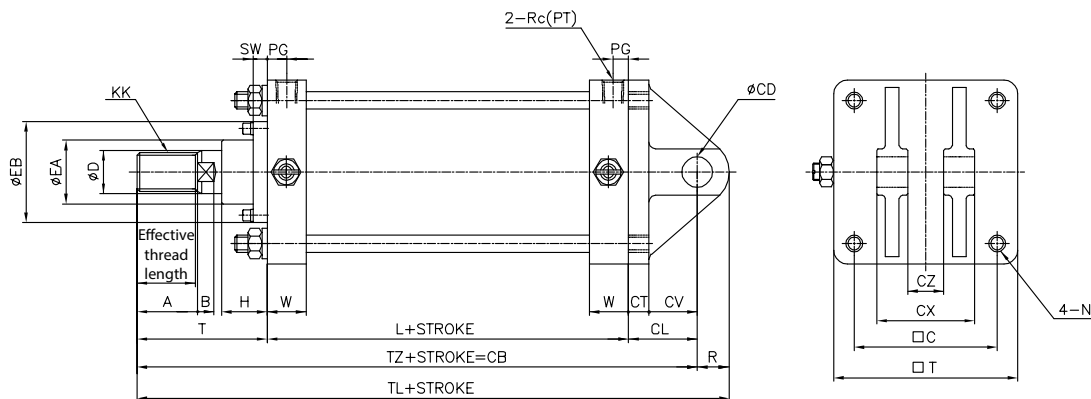

Unit : mm

Bore size	Effective thread length	A	B	□C	ØCD	CL	CT	CV	CX	CZ	ØD	ØEA	ØEB	H
Ø125	47	50	15	115	25 ^{+0.15} / _{+0.10}	65	17	48	64	32 ^{+0.3} / _{+0.1}	35	59	70	42
Ø140	47	50	15	128	28 ^{+0.15} / _{+0.10}	75	17	58	72	36 ^{+0.3} / _{+0.1}	35	59	-	42
Ø150	53	56	17	132	32 ^{+0.15} / _{+0.10}	80	20	60	80	40 ^{+0.3} / _{+0.1}	40	59	-	43
Ø160	53	56	17	144	32 ^{+0.15} / _{+0.10}	80	20	60	80	40 ^{+0.3} / _{+0.1}	40	59	-	43
Ø180	60	63	20	162	40 ^{+0.15} / _{+0.10}	90	23	67	100	50 ^{+0.3} / _{+0.1}	45	70	85	48
Ø200	60	63	20	182	40 ^{+0.15} / _{+0.10}	90	25	65	100	50 ^{+0.3} / _{+0.1}	50	74	85	48
Ø250	67	71	25	225	50 ^{+0.15} / _{+0.10}	110	30	80	126	63 ^{+0.3} / _{+0.1}	60	96	140	60
Ø300	76	80	30	270	63 ^{+0.15} / _{+0.10}	130	37	93	160	80 ^{+0.3} / _{+0.1}	70	96	140	60

Bore size	KK	L	N	PG	R	Rc(PT)	SW	□T	T	TL	TZ	W
Ø125	M30X1.5	98	M14X1.5	16	(29)	1/2	10	145	110	302	273	32
Ø140	M30X1.5	98	M14X1.5	16	(32)	1/2	-	161	110	315	283	32
Ø150	M36X1.5	106	M16X1.5	17.5	(36)	3/4	-	170	120	342	306	36
Ø160	M36X1.5	106	M16X1.5	17	(36)	3/4	-	184	120	342	306	36
Ø180	M40X1.5	111	M18X1.5	18	(44)	3/4	17	204	135	380	336	39
Ø200	M45X1.5	111	M20X1.5	18	(44)	3/4	8	226	135	380	336	38
Ø250	M56X2.0	141	M24X1.5	22	(55)	1	20	277	160	466	411	49
Ø300	M64X2.0	146	M30X1.5	22	(68)	1	20	330	175	519	451	49

Pneumatic Cylinder

Reference Data

AJP

KGUA

ACP

ACD

ACS2

ACS3

ACS4

ACS5

ACR

ACM

ACL

ACX

KLC

KLCS

AF, ADF

AFG

FM, FMD

Custom-Made Rod Ends

Custom-Made Tie Rods

KBP

CCTS

Dimensions-Center Trunnion (TC), Rod Side Trunnion (TA), Head Side Trunnion (TB)

Ø125, Ø140, Ø150, Ø160, Ø180, Ø200

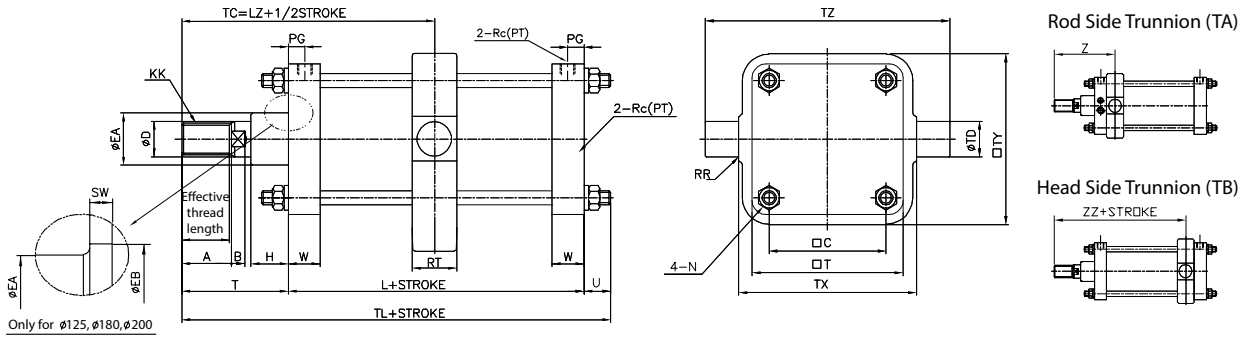

Ø250, Ø300

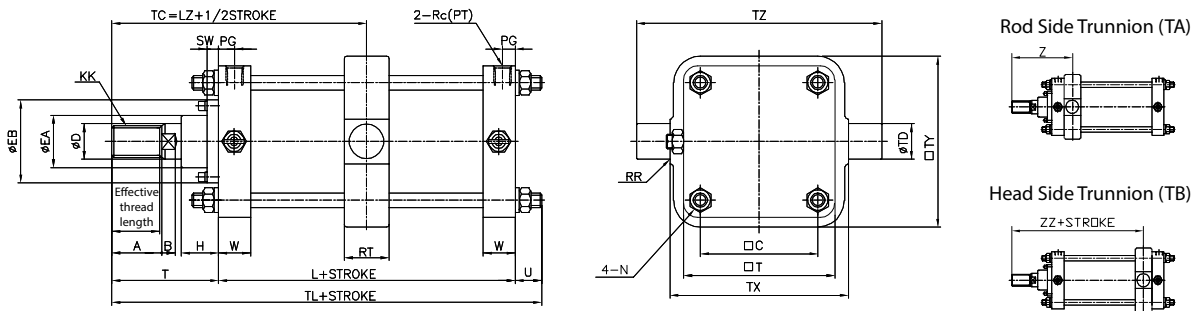

Unit : mm

Bore size	Effective thread length	A	B	□C	ØD	ØEA	ØEB	H	KK	L	LZ	N	PG	Rc(PT)
Ø125	47	50	15	115	35	59	70	42	M30X1.5	98	159	M14X1.5	16	1/2
Ø140	47	50	15	128	35	59	-	42	M30X1.5	98	159	M14X1.5	16	1/2
Ø150	53	56	17	132	40	59	-	43	M36X1.5	106	173	M16X1.5	17.5	3/4
Ø160	53	56	17	144	40	59	-	43	M36X1.5	106	173	M16X1.5	17	3/4
Ø180	60	63	20	162	45	70	85	48	M40X1.5	111	190.5	M18X1.5	18	3/4
Ø200	60	63	20	182	50	74	85	48	M45X1.5	111	190.5	M20X1.5	18	3/4
Ø250	67	71	25	225	60	96	140	60	M56X2.0	141	230.5	M24X1.5	22	1
Ø300	76	80	30	270	70	96	140	60	M64X2.0	146	248	M30X1.5	22	1

Bore size	RR	RT	SW	□T	T	ØTD	TL	TX	ØTY	TZ	U	W	Z	ZZ
Ø125	1	50	10	145	110	32 ^{-0.05/-0.10}	227	170	164	234	(19)	34	170	148
Ø140	1.5	55	-	161	110	36 ^{-0.05/-0.10}	227	190	184	262	(21.5)	34	172.5	145.5
Ø150	1.5	59	-	170	120	40 ^{-0.05/-0.10}	248	200	192	275	(22.5)	38	188.5	157.5
Ø160	1.5	59	-	184	120	40 ^{-0.05/-0.10}	248	212	204	292	(22.5)	38	189	157
Ø180	2	60	17	204	135	45 ^{-0.05/-0.10}	272.5	236	228	326	(24.5)	39	204	177
Ø200	2	60	8	226	135	45 ^{-0.05/-0.10}	272.5	265	257	355	(25.5)	38	204	177
Ø250	3	69	20	277	160	56 ^{-0.05/-0.10}	332.1	335	325	447	(30)	49	243.5	217.5
Ø300	4	79	20	330	175	67 ^{-0.05/-0.10}	357	400	390	534	(36.5)	49	263.5	232.5

Dimensions-Accessory

Single Knuckle Joint

Material: Free-cutting steel

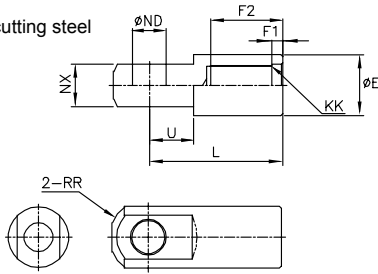

Unit : mm

Part no.	Bore size	ØE	F1	F2	KK	L	ØND
I125	125	46	8	54	M30X1.5	100	25 ^{+0.1} ₀
I140	140	48	8	54	M30X1.5	105	28 ^{+0.1} ₀
I150	150, 160	55	8	60	M36X1.5	110	32 ^{+0.1} ₀
I180	180	70	8	67	M40X1.5	125	40 ^{+0.1} ₀
I200	200	70	8	67	M45X1.5	125	40 ^{+0.1} ₀
I250	250	85	8	75.5	M56X2.0	160	50 ^{+0.1} ₀
I300	300	105	8	84.5	M64X2.0	175	63 ^{+0.1} ₀

Part no.	NX	RR	U
I125	32 ^{-0.1} _{-0.3}	27	33
I140	36 ^{-0.1} _{-0.3}	30	39
I150	40 ^{-0.1} _{-0.3}	34	39
I180	50 ^{-0.1} _{-0.3}	42.5	44
I200	50 ^{-0.1} _{-0.3}	42.5	44
I250	63 ^{-0.1} _{-0.3}	53	66
I300	80 ^{-0.1} _{-0.3}	66	71

Double Knuckle Joint

Material: FC 40

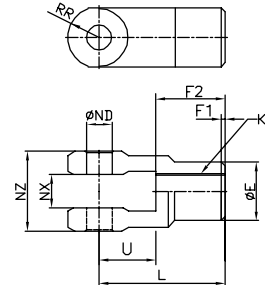

Unit : mm

Part no.	Bore size	ØE	F1	F2	KK	L	ØND
Y125	125	46	8	58	M30X1.5	100	25 ^{+0.1} ₀
Y140	140	48	8	58	M30X1.5	105	28 ^{+0.1} ₀
Y150	150, 160	55	8	64	M36X1.5	110	32 ^{+0.1} ₀
Y180	180	70	8	71	M40X1.5	125	40 ^{+0.1} ₀
Y200	200	70	8	71	M45X1.5	125	40 ^{+0.1} ₀
Y250	250	86	9	79	M56X2.0	160	50 ^{+0.1} ₀
Y300	300	105	9	88	M64X2.0	175	63 ^{+0.1} ₀

Part no.	NX	NZ	RR	U
Y125	32 ^{+0.3} _{+0.1}	64 ^{-0.1} _{-0.3}	27	42
Y140	36 ^{+0.3} _{+0.1}	72 ^{-0.1} _{-0.3}	30	47
Y150	40 ^{+0.3} _{+0.1}	80 ^{-0.1} _{-0.3}	34	46
Y180	50 ^{+0.3} _{+0.1}	100 ^{-0.1} _{-0.3}	42.5	54
Y200	50 ^{+0.3} _{+0.1}	100 ^{-0.1} _{-0.3}	42.5	54
Y250	63 ^{+0.3} _{+0.1}	126 ^{-0.1} _{-0.3}	53	81
Y300	80 ^{+0.3} _{+0.1}	160 ^{-0.1} _{-0.3}	66	87

Rod End Nut

Material: Rolled steel

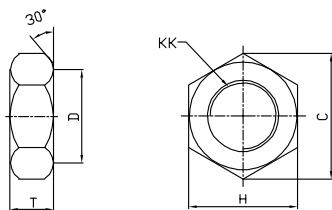

Unit : mm

Part no.	Bore size	C	D	H	KK	T
RN-12	125, 140	53.1	44	46	M30X1.5	18
RN-15	150, 160	63.5	53	55	M36X1.5	21
RN-18	180	69.3	57	60	M40X1.5	23
RN-20	200	80.8	67	70	M45X1.5	27
RN-25	250	98.1	82	85	M56X2.0	34
RN-30	300	110	92	95	M64X2.0	38

Knuckle Joint Pin/ Clevis Pin

Material: Carbon Steel

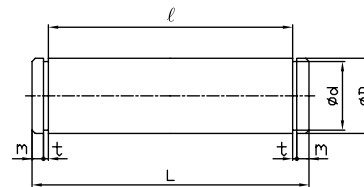

Unit : mm

Part no.	Bore size	ØD	Ød	L	l	m	t
CJP-12	125	25 ^{-0.06} _{-0.11}	23.9 ⁰ _{-0.21}	72	64.3	2.5	1.35
CJP-14	140	28 ^{-0.06} _{-0.11}	26.6 ⁰ _{-0.21}	80.6	72.3	2.5	1.65
CJP-15	150, 160	32 ^{-0.08} _{-0.14}	30.3 ⁰ _{-0.25}	89.6	80.3	3	1.65
CJP-18	180, 200	40 ^{-0.08} _{-0.14}	38 ⁰ _{-0.25}	110.1	100.3	3	1.9
CJP-25	250	50 ^{-0.08} _{-0.11}	47 ⁰ _{-0.25}	138.9	126.5	4	2.2
CJP-30	300	63 ^{-0.10} _{-0.17}	60 ⁰ _{-0.3}	172.9	160.5	4	2.2

Pneumatic
Cylinder

Reference
Data

AJP

KGUA

ACP

ACD

ACS2

ACS3

ACS4

ACS5

ACR

ACM

ACL

ACX

KLC

KLCS

AF, ADF

AFG

FM, FMD

Custom-
Made
Rod Ends

Custom-
Made
Tie Rods

KBP

CCTS

Dimensions-Bellows Attached Type (J, K)

Ø125, Ø140, Ø150, Ø160, Ø180, Ø200

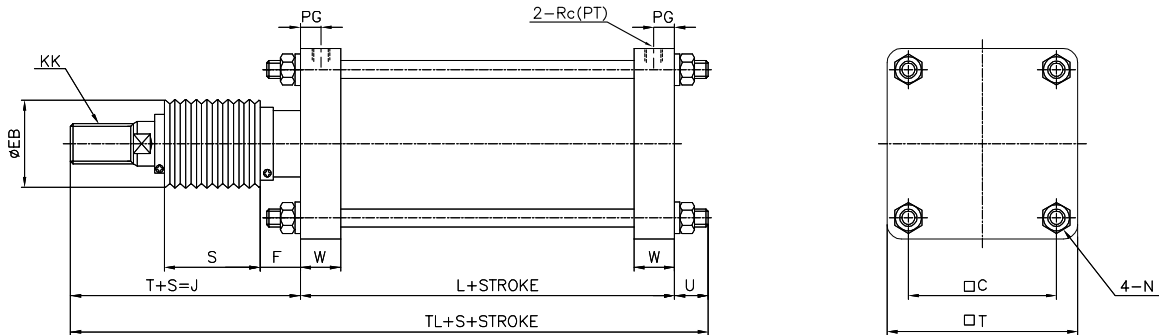

Ø250, Ø300

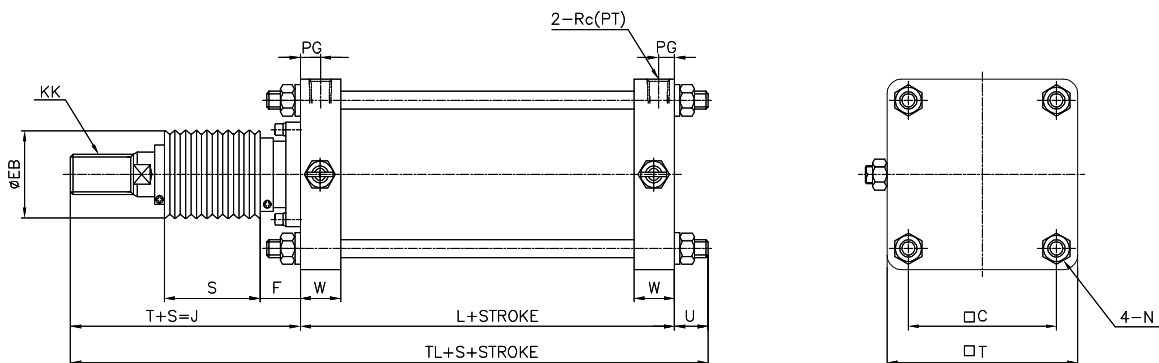

Unit : mm

Bore size	□C	ØEB	F	KK	N	L	PG	Rc(PT)	S	T	□T	TL	U	W
Ø125	115	75	40	M30X1.5	M14X1.5	98	16	1/2	0.2 X Stroke	133	145	258	(21)	32
Ø140	128	75	40	M30X1.5	M14X1.5	98	16	1/2		133	161	258	(21)	32
Ø150	132	75	40	M36X1.5	M16X1.5	106	17.5	3/4		141	170	277.5	(23)	36
Ø160	144	75	40	M36X1.5	M16X1.5	106	17	3/4		141	184	277.5	(23)	36
Ø180	162	85	45	M40X1.5	M18X1.5	111	18	3/4		153	204	299	(26)	39
Ø200	182	90	45	M45X1.5	M20X1.5	111	18	3/4		153	226	299	(30)	38
Ø250	225	105	55	M56X2.0	M24X1.5	141	22	1	0.17 X Stroke	176	277	358.5	(34)	49
Ø300	270	115	55	M64X2.0	M30X1.5	146	22	1		190	330	387.5	(36.5)	49

※ For dimensions not shown in these figures, refer to the ACL (Standard) type.
 ※ SUS band is mounted at bellows at delivery.

Type	J	K
Material	Nylon Tarpaulin	Neoprene Cloth
Temperature	60℃	110℃

Dimensions-Double Rod (ACLW)

Ø125, Ø140, Ø150, Ø160, Ø180, Ø200

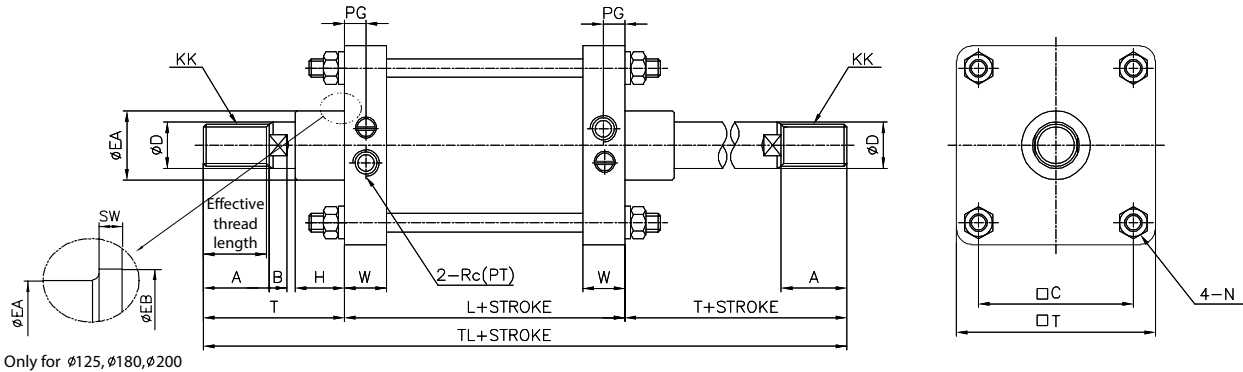

Only for Ø125, Ø180, Ø200

Ø250, Ø300

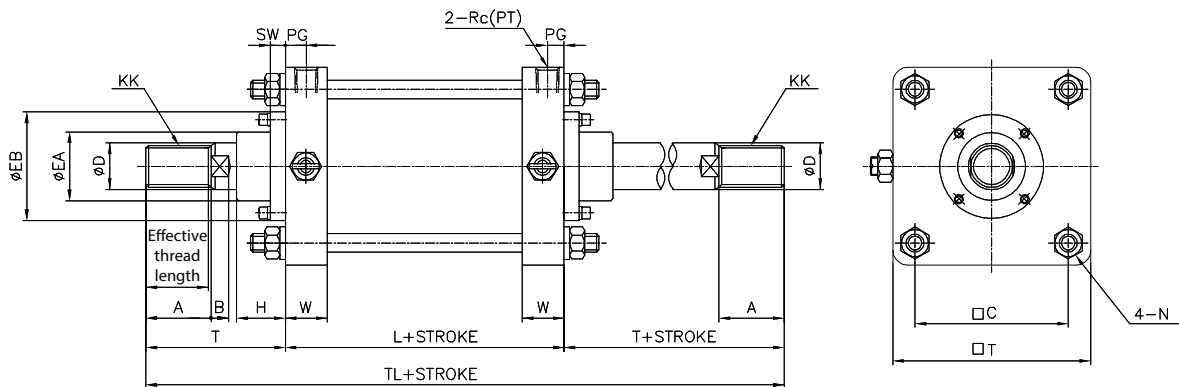

Unit : mm

Bore size	Effective thread length	A	B	□C	ØD	ØEA	ØEB	H	KK	L	N	PG	Rc(PT)	SW
Ø125	47	50	15	115	35	59	70	42	M30X1.5	98	M14X1.5	16	1/2	10
Ø140	47	50	15	128	35	59	-	42	M30X1.5	98	M14X1.5	16	1/2	-
Ø150	53	56	17	132	40	59	-	43	M36X1.5	106	M16X1.5	17.5	3/4	-
Ø160	53	56	17	144	40	59	-	43	M36X1.5	106	M16X1.5	17	3/4	-
Ø180	60	63	20	162	45	70	85	48	M40X1.5	111	M18X1.5	18	3/4	17
Ø200	60	63	20	182	50	74	85	48	M45X1.5	111	M20X1.5	18	3/4	8
Ø250	67	71	25	225	60	96	140	60	M56X2.0	141	M24X1.5	22	1	20
Ø300	76	80	30	270	70	96	140	60	M64X2.0	146	M30X1.5	22	1	20

Bore size	□T	T	TL	W
Ø125	145	110	318	32
Ø140	161	110	318	32
Ø150	170	120	346	36
Ø160	184	120	346	36
Ø180	204	135	381	39
Ø200	226	135	381	38
Ø250	277	160	461	49
Ø300	330	175	496	49

Pneumatic Cylinder

Reference Data

AJP

KGUA

ACP

ACD

ACS2

ACS3

ACS4

ACS5

ACR

ACM

ACL

ACX

KLC

KLCS

AF, ADF

AFG

FM, FMD

Custom-Made Rod Ends

Custom-Made Tie Rods

KBP

CCTS

Single Rod Multi-Step Stroke Cylinder (TS)

By integrating two cylinders in series enable back and forth stroke and two-steps control for a doubled output.

Ordering notation: A Stroke + Total Stroke

Ex) 150 + 200 (A Side = 150, B Side = 50)

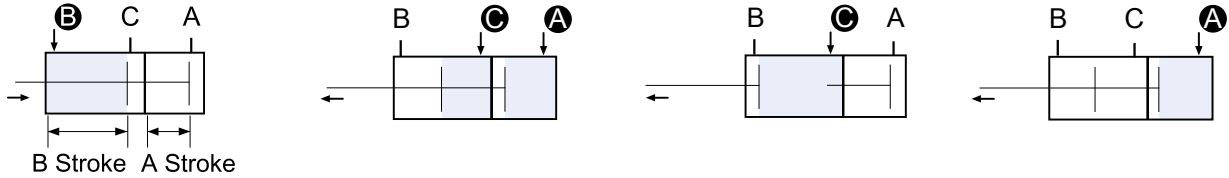

When B port is supplied with air pressure, A and B strokes reverse.

When both A and C ports are supplied with air pressure, forward output is doubled.

When C port is supplied with air pressure, rod and B Stroke move forward.

When A port is supplied with air pressure, rod and A Stroke move forward.

Dimensions-Single Rod Multi-Step Stroke Cylinder (TS)

Ø125, Ø140, Ø150, Ø160, Ø180, Ø200

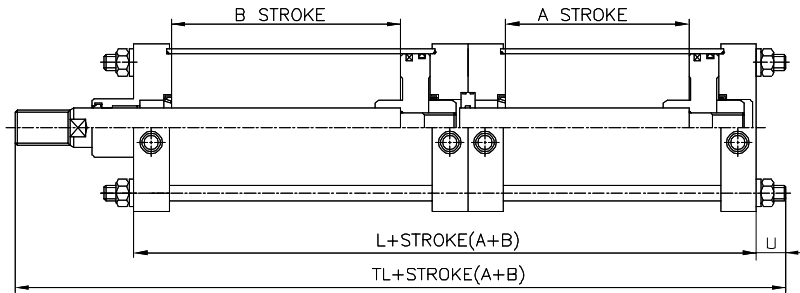
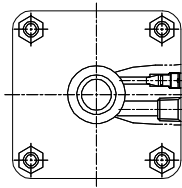

Ø250, Ø300

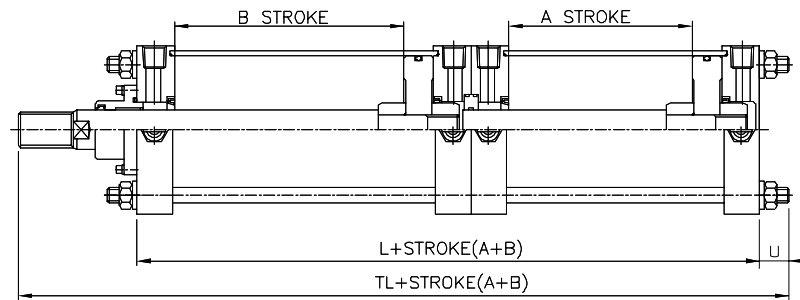
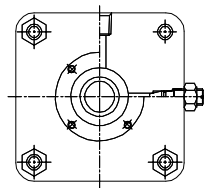

Unit : mm

Bore size	L	TL	U
Ø125	197	334	(21)
Ø140	197	334	(21)
Ø150	213	363.5	(23)
Ø160	213	363.5	(23)
Ø180	223	393	(26)
Ø200	223	393	(30)
Ø250	283	484.5	(34)
Ø300	293	519.5	(41.5)

* For dimensions not shown in these figures, refer to the ACL (Standard) type.

Double Rod Multi-Step Stroke Cylinder (TW)

Head side assembly. By integrating two cylinders enable back and forth stroke and three steps control.

Ordering notation: A Stroke + B Stroke

Example) 150 + 50 (A Side = 150, B Side = 50)

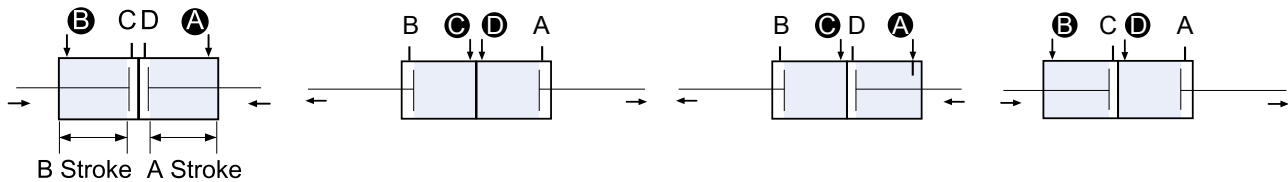

When A and B ports are supplied with air pressure, A and B strokes reverse.

When C and D ports are supplied with air pressure, A and B strokes move forward.

When A and C ports are supplied with air pressure, B stroke move forward.

When B and D ports are supplied with air pressure, A stroke move forward.

Dimensions-Double Rod Multi-Step Stroke Cylinder (TW)

Ø125, Ø140, Ø150, Ø160, Ø180, Ø200

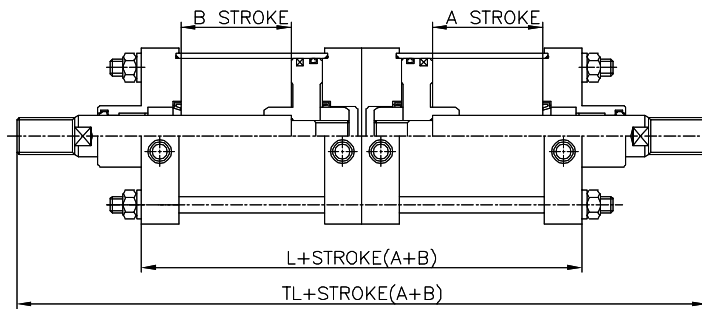
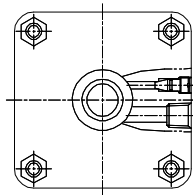

Ø250, Ø300

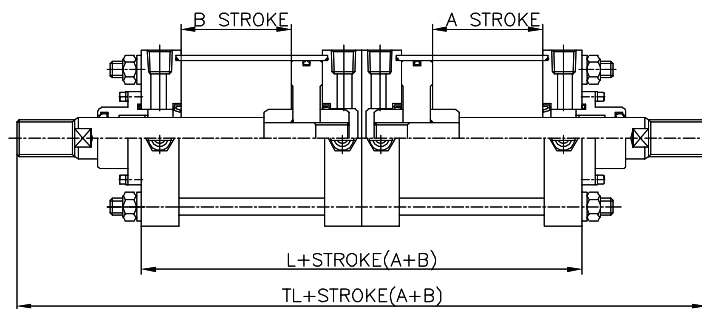
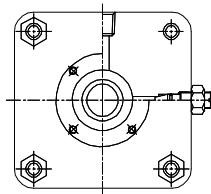

Unit : mm

Bore size	L	TL
Ø125	196	416
Ø140	196	416
Ø150	212	452
Ø160	212	452
Ø180	222	492
Ø200	222	492
Ø250	282	602
Ø300	292	642

※ For dimensions not shown in these figures, refer to the ACL (Standard) type.

Tandem Cylinder (TD)

Two cylinders connected in series for a doubled output.



When A and B ports are supplied with air pressure, reverse operating output is doubled.

When A and C ports are supplied with air pressure, forward operating output is doubled.

Dimensions-Tandem Cylinder (TD)

Ø125, Ø140, Ø150, Ø160, Ø180, Ø200

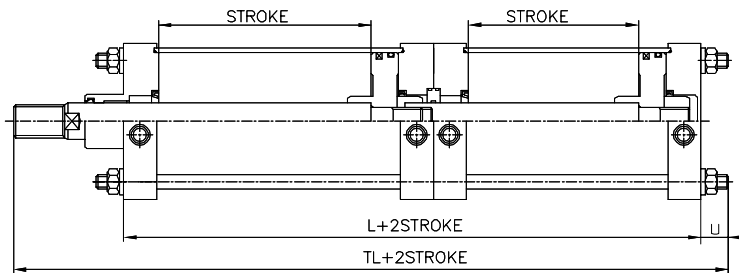
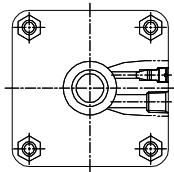

Ø250, Ø300

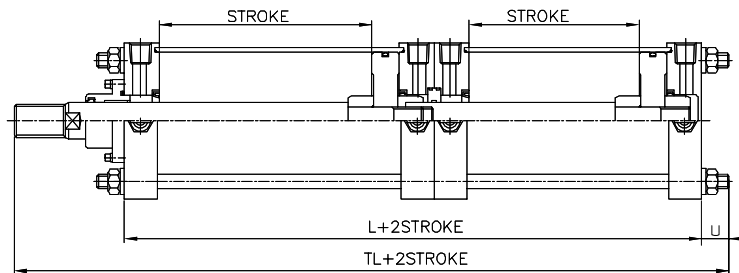
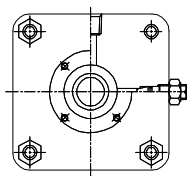

Unit : mm

Bore size	L	TL	U
Ø125	196	333	(21)
Ø140	196	333	(21)
Ø150	212	362.5	(23)
Ø160	212	362.5	(23)
Ø180	222	392	(26)
Ø200	222	392	(30)
Ø250	282	483.5	(34)
Ø300	292	518.5	(41.5)

※ For dimensions not shown in these figures, refer to the ACL (Standard) type.

Forward Stroke Adjustable Cylinder (ASJ, BSJ)

To adjust the entire forward stroke from 0mm to 50mm an adjustment mechanism is attached to the head side.

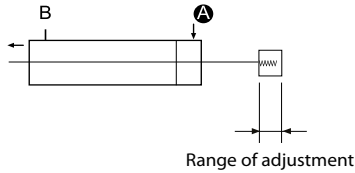

ASJ : 25mm adjustment
BSJ : 50mm adjustment
XSJ : Xmm adjustment (X is defined by user)

Dimensions-Forward Stroke Adjustable (ASJ, BSJ)

Ø125, Ø140, Ø150, Ø160, Ø180, Ø200

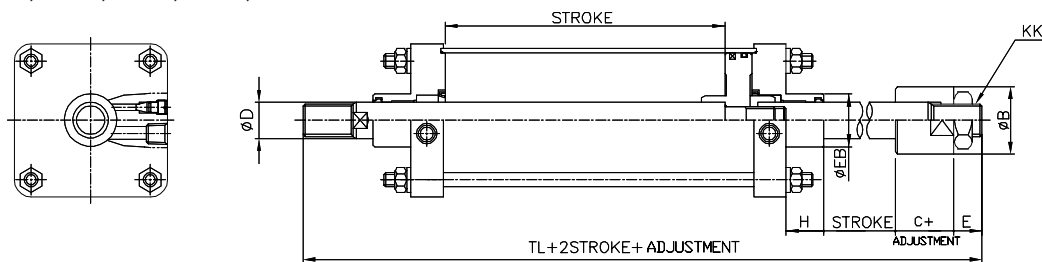

Ø250, Ø300

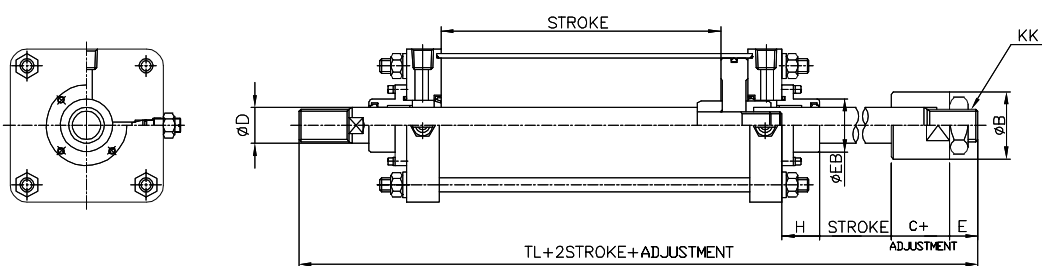

Unit : mm

Bore size	ØB	C	ØD	E	ØEB	H	KK	TL
Ø125	60	37	35	39	90	43	M30X1.5	318
Ø140	60	37	35	30	90	43	M30X1.5	318
Ø150	60	46	40	26	90	43	M36X1.5	341
Ø160	60	46	40	26	90	43	M36X1.5	341
Ø180	70	52	45	30	115	48	M40X1.5	376
Ø200	70	52	50	30	115	48	M45X1.5	376
Ø250	86	60	60	35	140	60	M56X2.0	456
Ø300	86	60	70	35	140	60	M64X2.0	496

※ For dimensions not shown in these figures, refer to the ACL standard type.

Heat Resistant Cylinder (SV)

Heat resistant cylinder can be used at a high ambient temperature up to 150°C by equipped with heat-resistant seal.

Specification

Type	Lubricated type
Bore size	Ø125, Ø140, Ø150, Ø160, Ø180, Ø200
Ambient temperature	-20 ~ 150°C
Packing material	VITON

Stainless Steel Piston Rod (SS)

Stainless steel cylinder rod is selected to prevent the end of rod from corrosion when it is in contact with water during operation.

Specification

Type	Lubricated type, Non-Lubricated type
Bore size	Ø125, Ø140, Ø150, Ø160, Ø180, Ø200, Ø250, Ø300
Rod material	SUS304

Pneumatic Cylinder

Reference Data

AJP

KGUA

ACP

ACD

ACS2

ACS3

ACS4

ACS5

ACR

ACM

ACL

ACX

KLC

KLCS

AF, ADF

AFG

FM, FMD

Custom-Made Rod Ends
Custom-Made Tie Rods

KBP

CCTS