

ACP series



Features

- Build-in magnet (Standard)
- Easy to install with its compact size.
- Piston rod with small deflection.

Symbol	
Double Acting / Single Rod	Single Acting / Spring Return
Double Acting / Double Rod	Single Acting / Spring Extend

How to Order

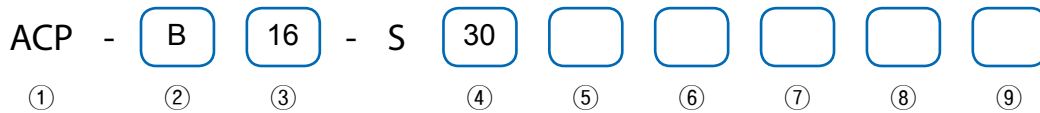

① Series

ACP	Single rod small pin cylinder
ACPW	Double rod small pin cylinder

② Mounting style

B	Standard
LB	Foot
FA	Flange
CB	Double clevis (Except Ø6)

③ Bore size

6	6mm
10	10mm
16	16mm

④ Cylinder stroke

Action Bore size	Double acting	Double rod	Single rod
	5, 10, 15, 20, 25, 30, 35, 40, 45, 50, 60, 70, 75, 100	-	15, 30, 45, 60
5, 10, 15, 20, 25, 30, 35, 40, 45, 50, 60, 70, 75, 100, 125, 150	15, 30, 45, 60	15, 30, 45, 60	
5, 10, 15, 20, 25, 30, 35, 40, 45, 50, 60, 70, 75, 100, 125, 150, 175, 200	15, 30, 45, 60	15, 30, 45, 60	

* Refer to page [1]-133, for specifications about custom-made rod ends.

⑤ Head cover position

	Ø6	Ø10, Ø16
Nil	Axial (Standard)	90° from axial
R	-	Axial

* Not available for double rod and CB mounting type.

⑥ Action

Nil	Double acting
S	Single acting spring return
T	Single acting spring extend

* Not available for double rod type.

⑦ Accessory

Nil	Rod end nut (Standard) :2 pc
I	Single knuckle joint
Y	Double knuckle joint

⑧ Auto switch

Reed A/S	Model	Solid State A/S	Model
Nil	None	Nil	None
C72	D-C72K	H7A1	D-H7A1K
C73	D-C73K	H7A2	D-H7A2K
C76	D-C76K	H7B	D-H7BK
C80	D-C80K		

* Refer to Auto Switch Catalogue for more information.

⑨ Number of auto switches

Nil	2 pcs
1	1 pc
N	N pcs (N: 3, 4, 5...)

* Only for auto switch attached type.

Specifications

Action	Double acting, Single rod	Double acting, Double rod	Single acting, Spring return	Single acting, Spring extend
Fluid	Air			
Proof pressure	10.5kgf/cm ² (1.05MPa)			
Max. operating pressure	7.0kgf/cm ² (700kPa)			
Min. operating pressure	Ø6	1.2kgf/cm ² (120kPa)	1.5kgf/cm ² (150kPa)	2.0kgf/cm ² (200kPa)
	Ø10, Ø16	0.6kgf/cm ² (60kPa)	1kgf/cm ² (100kPa)	1.5kgf/cm ² (150kPa)
Ambient & fluid temperature	5°C ~ 60°C			
Operating piston speed	50 ~ 750mm/sec			
Cushion	Rubber bumper			
Lubrication	Not required			
Tolerance of thread	KS class 2			
Tolerance of stroke	+1.0 0			

Mounting Style & Option

Mounting style		Standard	Foot	Flange	Double Clevis
Standard mounting	Mounting nut	•	•	•	-
	Rod end nut	•	•	•	•
	Clevis pin	-	-	-	•
Option	Single knuckle joint	•	•	•	•
	Double knuckle joint	•	•	•	•

※ For double clevis and double knuckle joint, pin and snap ring are included.
 ※ Double clevis is not applicable to double rod type.

Mounting

Mounting	Bore size		
	Ø6	Ø10	Ø16
Foot mounting	ACP B6-LB	ACP B10-LB	ACP B16-LB
Flange mounting	ACP B6-FA	ACP B10-FA	ACP B16-FA

Accessory

Accessory	Ø10	Ø16
Single knuckle joint	ACP B10-I	ACP B16-I
Double knuckle joint	ACP B10-Y	ACP B16-Y

Position of Port on Head Cover

For standard type, position of head cover port is on axial direction or perpendicular to axial direction. But, Ø6 type only available on axial direction.

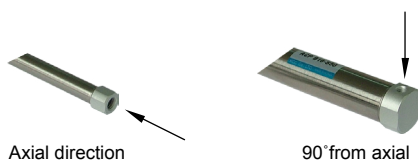

Spring Return Force

Bore size	Beginning of return	End of return
Ø6	3.72	1.77
Ø10	6.86	3.53
Ø16	14.2	6.86

Mass

Bore size (mm)		Double Acting Single Rod			Double Acting Double Rod		
		Ø6	Ø10	Ø16	Ø6	Ø10	Ø16
Basic mass		15	24	55	27	35	70
Additional mass for each 15mm stroke		2	4	6.5	3	6	9
Mounting mass	Foot	8	8	20	16	16	40
	Flange	5	5	15	5	5	15
	Double clevis (with pin)	-	4	10	-	-	-
Accessory	Single knuckle joint	-	16	24	-	-	-
	Double knuckle joint (with pin)	-	24	22	-	-	-

Bore size		Spring return (Forward)			Spring extend (Reverse)		
		Ø6	Ø10	Ø16	Ø6	Ø10	Ø16
Basic mass	15 Stroke	11	28	63	17	28	64
	30 Stroke	16	35	80	21	34	80
	45 Stroke	18	44	102	23	43	100
	60 Stroke	23	53	124	27	51	121
	75 Stroke	-	-	145	-	-	140
	100 Stroke	-	-	188	-	-	178
	125 Stroke	-	-	224	-	-	212
150 Stroke	-	-	250	-	-	236	

※ Basic mass does include the mass of mounting nut and rod end nut.
 ※ Mass of double clevis does not include the mass of mounting nut.

Calculation:

1. Standard type

Ex) ACP-LB10-S45
 Basic mass: 24(Ø10) / Additional mass: 4/15
 Cylinder stroke: 45mm
 Mass of mounting: 8(Axial foot type)
 24+(4/15×45)+8=44g

2. Single acting spring return type

Ex) ACP-LB10-S45T
 Basic mass: 43(Ø10, 45 Stroke) / Mas of mounting: 8(Axial foot type)
 43+8=51g

Structure

Double Acting, Single Rod
Ø6

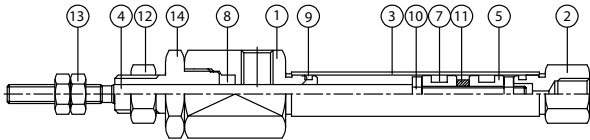

Double Acting, Single Rod
Ø10, Ø16

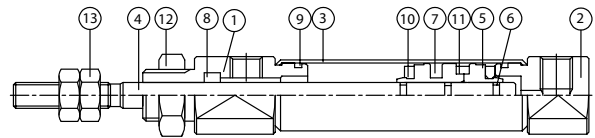

Double Acting, Double Rod

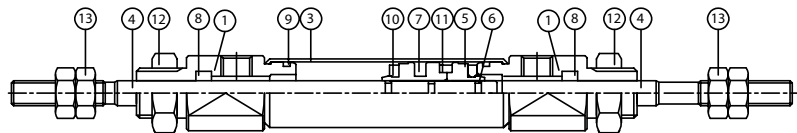

Single Acting Spring Return

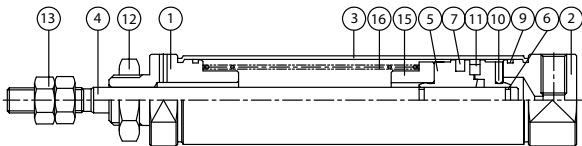

Single Acting Spring Extend

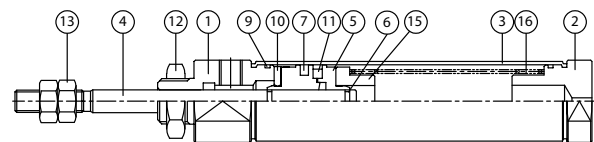

Part no.	Parts	Material	Part no.	Parts	Material
1	Rod Cover	AL	9	Guide Packing	NBR
2	Head Cover	AL	10	Damper	Urethane
3	Cylinder Tube	SUS	11	Magnet	Nd-Fe-B
4	Piston Rod	SUS	12	Mounting Nut	MBSBE
5	Piston	MBSBE	13	Rod End Nut	-
6	O-Ring	NBR	14	Packing Retainer	AL
7	Piston Packing	NBR	15	Spring Guide	AL
8	Rod Packing	NBR	16	Spring	-

Dimensions-Double Acting/Standard (B)

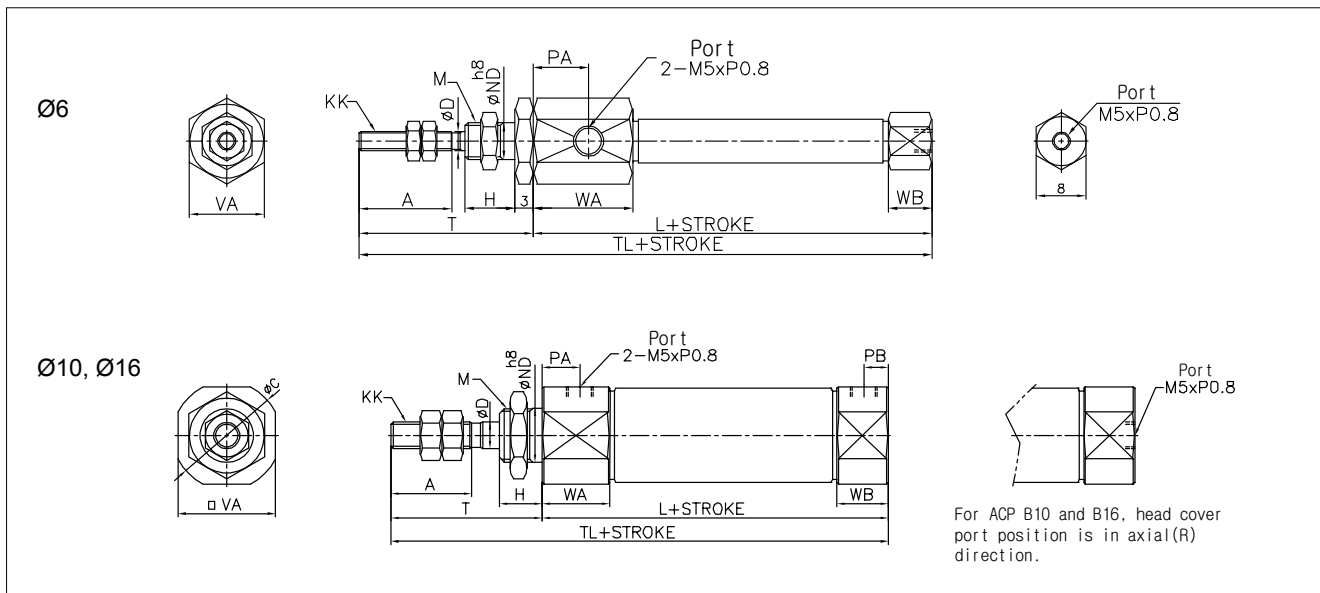

Unit : mm

Bore size	A	ØC	ØD	H	KK	L	M	ØND ^{h8}	PA	PB	T	TL	□VA	WA	WB
Ø6	15	14	3	8	M3X0.5	49	M6X1.0	6 ⁰ _{-0.018}	14.5	-	28	77	12	16	7
Ø10	15	14	4	8	M4X0.7	46	M8X1.0	8 ⁰ _{-0.022}	8	5	28	74	12	12.5	9.5
Ø16	15	20	5	8	M5X0.8	47	M10X1.0	10 ⁰ _{-0.022}	8	5	28	75	18	12.5	9.5

Dimensions-Double Acting/Foot (LB)

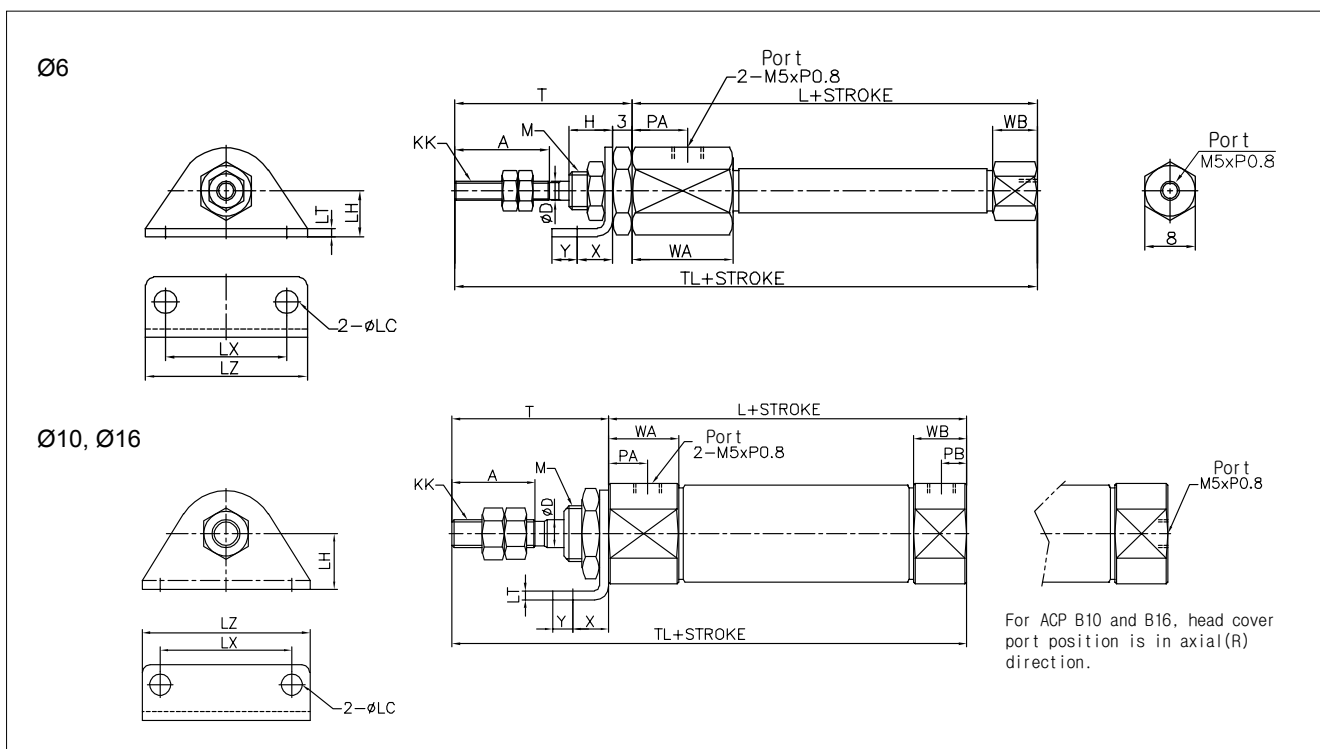

Unit : mm

Bore size	A	ØD	H	KK	L	ØLC	LH	LT	LX	LZ	M	PA	PB	T	TL	WA	WB	X	Y
Ø6	15	3	8	M3X0.5	49	4.5	9	1.6	24	32	M6XP1.0	14.5	-	28	77	16	7	7	5
Ø10	15	4	8	M4X0.7	46	4.5	9	1.6	24	32	M8XP1.0	8	5	28	74	12.5	9.5	7	5
Ø16	15	5	8	M5X0.8	47	5.5	14	2.3	33	42	M10XP1.0	8	5	28	75	12.5	9.5	9	5

Pneumatic Cylinder

Reference Data

AJP

KGUA

ACP

ACD

ACS2

ACS3

ACS4

ACS5

ACR

ACM

ACL

ACX

KLC

KLCS

AF, ADF

AFG

FM, FMD

Custom-Made Rod Ends

Custom-Made Tie Rods

KBP

CCTS

Dimensions-Double Acting/Double Clevis (CB)

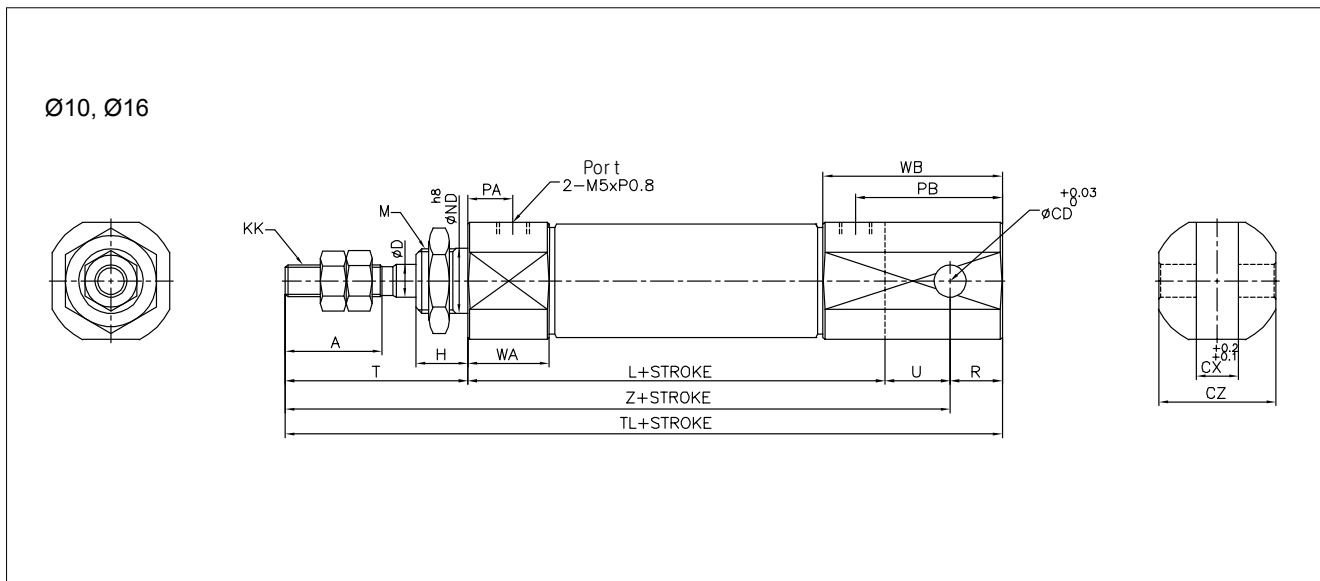

Unit : mm

Bore size	A	ØCD	CX	CZ	ØD	H	KK	L	M	PA	PB	R	T	TL	U	WA	WB	Z
Ø10	15	3.3	3.2	12	4	8	M4XP0.7	46	M8XP1.0	8	18	5	28	87	8	12.5	22.5	82
Ø16	15	5	6.5	18	5	8	M5XP0.8	47	M10XP1.0	8	23	8	28	93	10	12.5	27.5	85

Dimensions-Double Acting/Rod Side Flange (FA)

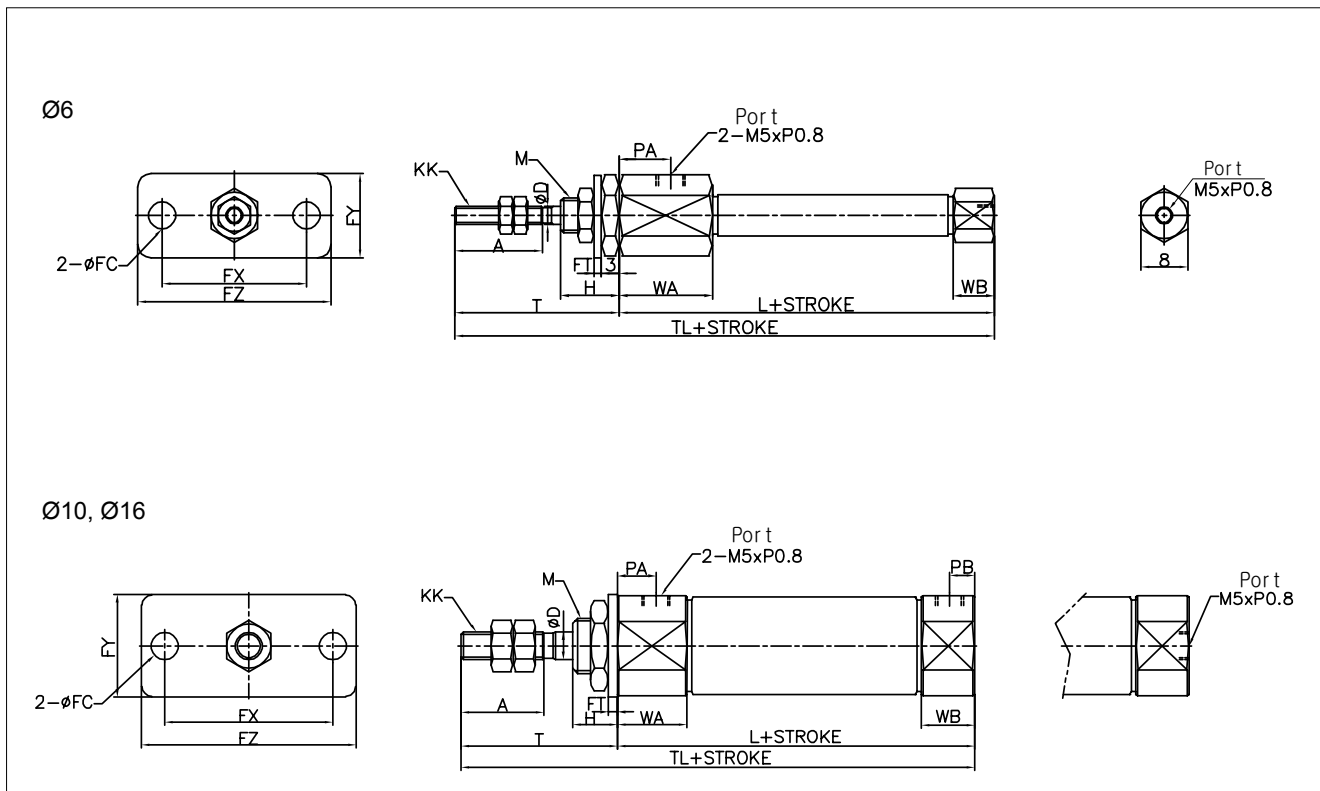

Unit : mm

Bore size	A	ØD	ØFC	FT	FX	FY	FZ	H	KK	L	M	PA	PB	T	TL	WA	WB
Ø6	15	3	Ø4.5	1.6	24	14	32	8	M3XP0.5	49	M6XP1.0	14.5	-	28	77	16	7
Ø10	15	4	Ø4.5	1.6	24	14	32	8	M4XP0.7	46	M8XP1.0	8	5	28	74	12.5	9.5
Ø16	15	5	Ø4.5	2.3	33	20	42	8	M4XP0.8	47	M10XP1.0	8	5	28	75	12.5	9.5

Dimensions-Double Acting/Double Rod (W)

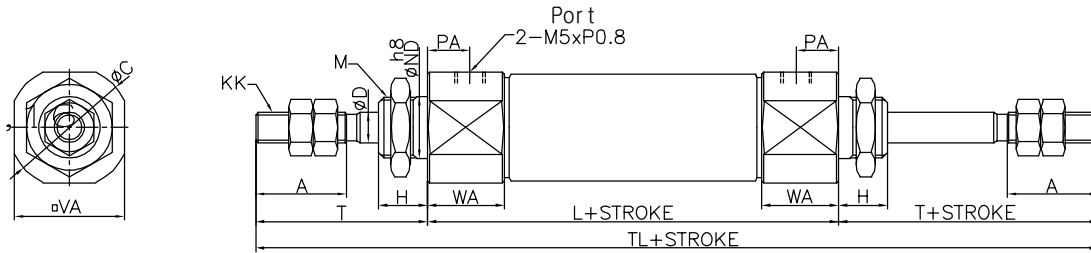

Unit : mm

Bore size	A	ØC	ØD	H	KK	L	M	ØND ^{h8}	PA	T	TL	□VA	WA
Ø10	15	14	4	8	M4X0.7	49	M8X1.0	8 ⁰ _{-0.022}	8	28	105	12	12.5
Ø16	15	20	5	8	M5X0.8	50	M10X1.0	10 ⁰ _{-0.022}	8	28	106	18	12.5

Dimensions-Single Acting Spring Return (S)

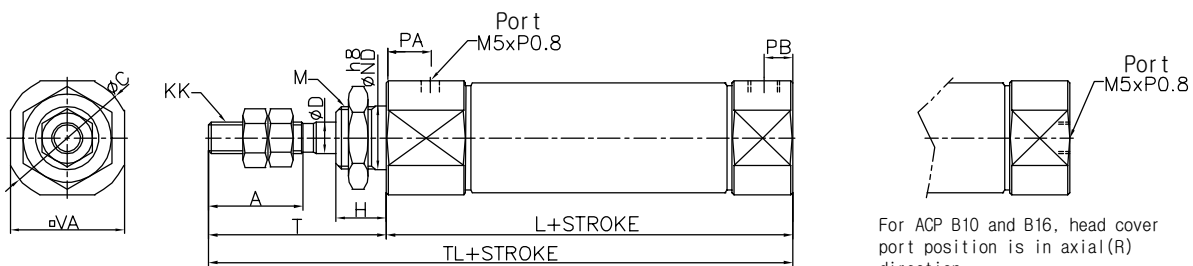

For ACP B10 and B16, head cover port position is in axial(R) direction.

Unit : mm

Bore size	A	ØC	ØD	H	KK	M	ØND ^{h8}	PA	PB	T	□VA	WA	WB	※L				※TL			
														5~15 ST	16~30 ST	31~45 ST	46~60 ST	5~15 ST	16~30 ST	31~45 ST	46~60 ST
Ø6	15	14	3	8	M3XP0.5	M6XP1.0	6 ⁰ _{-0.018}	14.5	-	28	8	16	7	39.5	48.5	52.5	66.5	67.5	76.5	80.5	94.5
Ø10	15	14	4	8	M4XP0.7	M8XP1.0	8 ⁰ _{-0.022}	8	5	28	12	12.5	9.5	46.5	54	66	78	74.5	82	94	106
Ø16	15	20	5	8	M5XP0.8	M10XP1.0	10 ⁰ _{-0.022}	8	5	28	18	12.5	9.5	46	54.5	66.5	78.5	74	82.5	94.5	106.5

Dimensions-Single Acting Spring Extend (T)

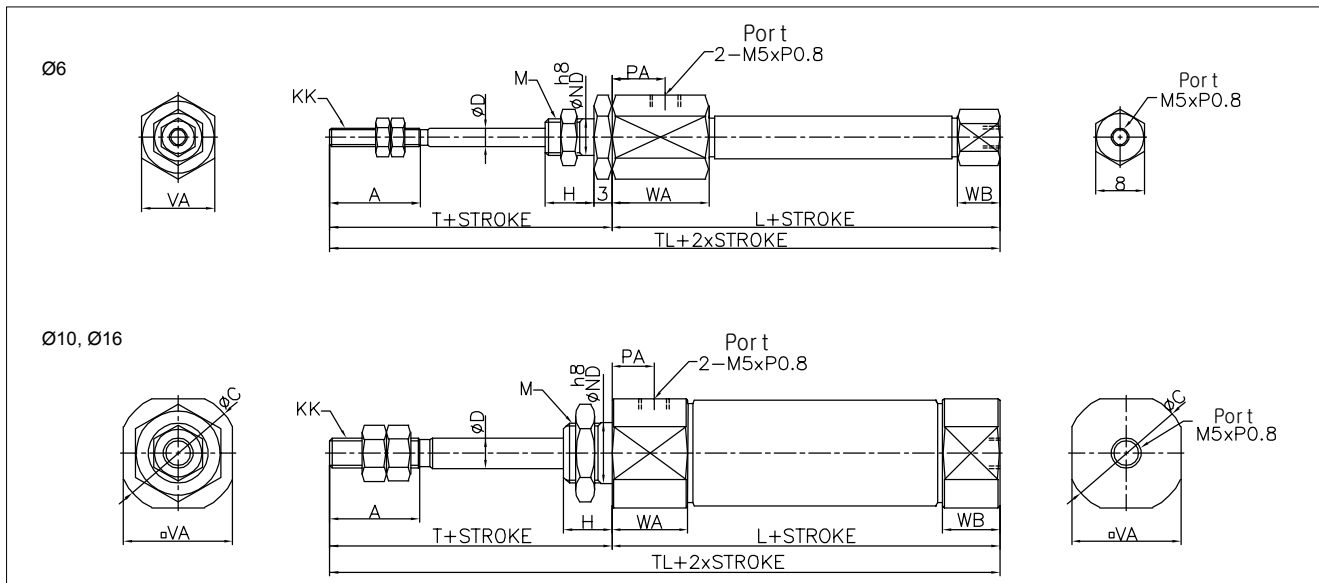

Unit : mm

Bore size	A	ØC	ØD	H	KK	M	ØND ^{h8}	PA	T	□VA	WA	WB
Ø6	15	14	3	8	M3XP0.5	M6XP1.0	6 ⁰ _{-0.018}	14.5	28	12	16	3
Ø10	15	14	4	8	M4XP0.7	M8XP1.0	8 ⁰ _{-0.022}	8	28	12	12.5	5.5
Ø16	15	20	5	8	M5XP0.8	M10XP1.0	10 ⁰ _{-0.022}	8	28	18	12.5	5.5

Bore size	※L				※TL			
	5~15 ST	16~30 ST	31~45 ST	46~60 ST	5~15 ST	16~30 ST	31~45 ST	46~60 ST
Ø6	51.5	60.5	64.5	78.5	79.5	88.5	92.5	106.5
Ø10	48.5	56	68	80	76.5	84	96	108
Ø16	48.5	57	69	81	76.5	85	97	109

Dimensions-Accessory

Pneumatic
Cylinder

Reference
Data

AJP

KGUA

ACP

ACD

ACS2

ACS3

ACS4

ACS5

ACR

ACM

ACL

ACX

KLC

KLCS

AF, ADF

AFG

FM, FMD

Custom-Made
Rod Ends
Custom-Made
Tie Rods

KBP

CCTS

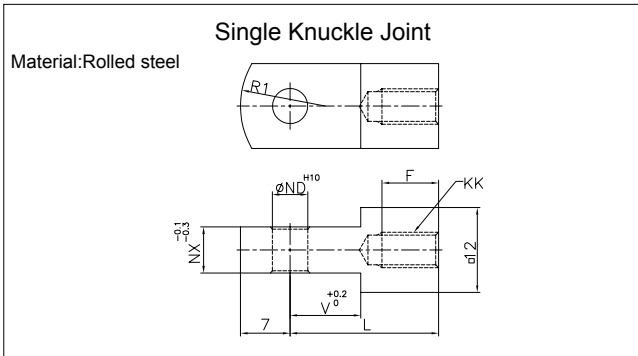

Part no.	Bore size	F	KK	L	ØND ^{H10}	NX	R1	V
ACP-B10-I	Ø10	8	M4XP0.7	21	3.3 ^{+0.048} ₀	3.1	8	9
ACP-B16-I	Ø16	8	M5XP0.8	25	5 ^{+0.048} ₀	6.4	12	14

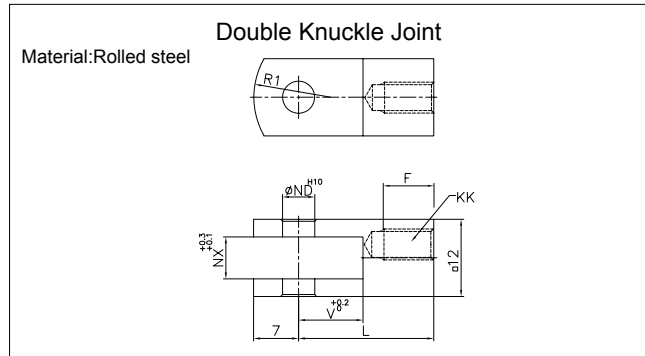

Part no.	Bore size	F	KK	L	ØND ^{H10}	NX	R1	V
ACP-B10-Y	Ø10	8	M4XP0.7	21	3.3 ^{+0.048} ₀	3.2	8	9
ACP-B16-Y	Ø16	11	M5XP0.8	25	5 ^{+0.048} ₀	6.5	12	14

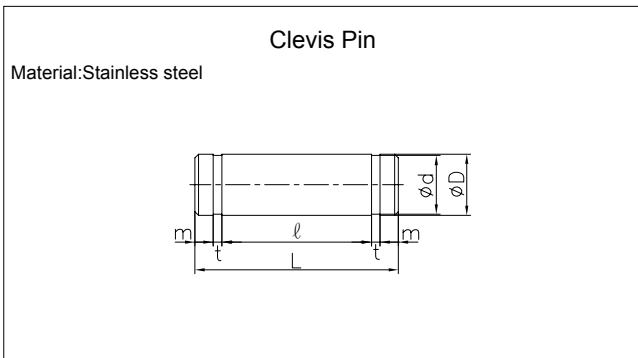

Part no.	Bore size	ØD ^{d9}	Ød	L	ℓ	m	t	Retaining Ring
CP-10	Ø10	3.3 ^{+0.030} _{+0.060}	2	15.2	12.2	1	0.5	E2
CP-16	Ø16	5 ^{+0.030} _{+0.060}	4	22.7	18.3	1.5	0.7	E4

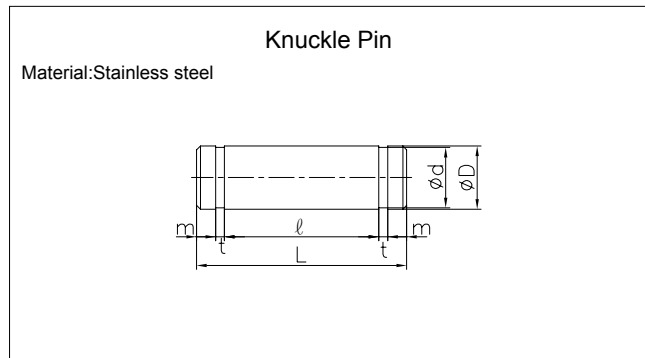

Part no.	Bore size	ØD ^{d9}	Ød	L	ℓ	m	t	Retaining Ring
JP-10	Ø10	3.3 ^{+0.030} _{+0.060}	2	15.2	12.2	1	0.5	E2
JP-16	Ø16	5 ^{+0.030} _{+0.060}	4	16.2	12.2	1.5	0.7	E4

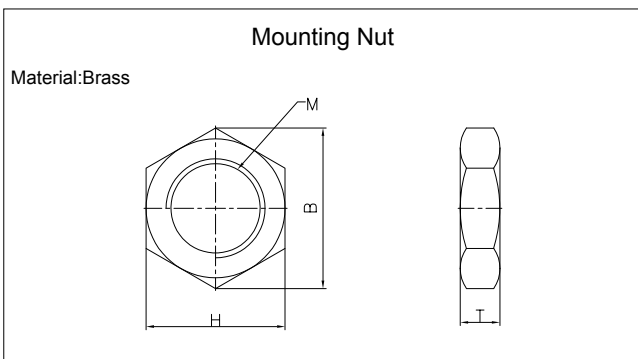

Part no.	Bore size	B	H	M	T
RN-06	Ø6	9.2	8	M6XP1.0	4
RN-10	Ø10	12.7	11	M8XP1.0	4
RN-16	Ø16	16.2	14	M10XP1.0	4

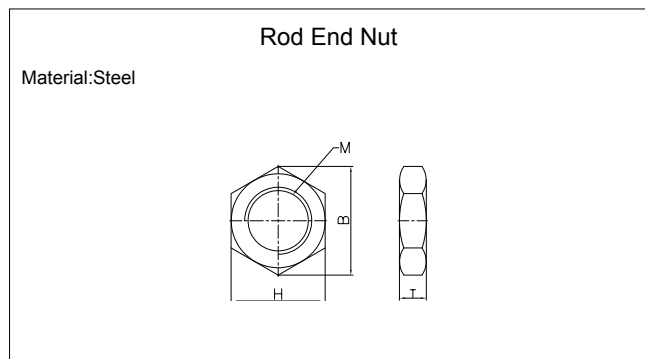

Part no.	Bore size	B	H	M	T
SN-06	Ø6	6.4	5.5	M3XP0.5	2.4
SN-10	Ø10	8.1	7	M4XP0.7	3.2
SN-16	Ø16	9.2	8	M5XP0.8	4