

Hand Valve (SHV)

SHV200~400 Series



SHV 210



SHV 300



SHV 400

How to order

SHV 2 0 0 - 02

- ① Hand valve
- ② Body size
2 - 1/4
3 - 3/8
4 - 1/2
- ③ Piping and Mounting Method

Mark	Piping	Mounting
0	Side	Body
1	Side	Panel
- ④ Number of Positions
0 - 3 position (Closed Center)
2 - 2 position
- ⑤ Thread type
Nil - Rc(PT)
N - NPT
G - G(PF)
- ⑥ Port size

Symbol	Size	Body size		
		2	3	4
02	1/4	●		
03	3/8		●	
04	1/2		●	●
06	3/4			●

Symbol

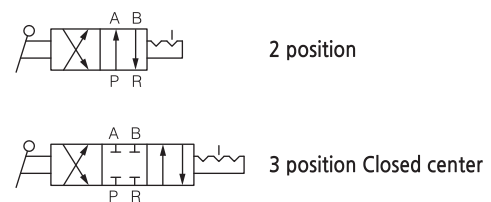

Specification

Fluid	Compressed Air
Max. supply pressure	15bar (15MPa)
Max. operating pressure	10bar (1MPa)
Ambient temperature	-5 ~ 60°C(No freezing)
Lubrication	Not required
Operating angle	90°

Precautions

- ① Ensure connection so that air is supplied to the "P" port. Air leakage may occur when the pressure is supplied from other ports
- ② Not suitable for negative pressure. The valve can malfunction due to air leakage.
- ③ When stopping the cylinder piston in the middle using the 3 position closed center valve, it is not possible to stop it correctly and precisely as the hydraulic equipment due to the air compressibility. Do not use this valve because it has slight air leakage and can not hold a stopping position.
- ④ The valve must be switched to each position instantly and securely. Stopping the handle halfway between the extreme positions may cause malfunction.

Series SHV200~400

DIMENSIONS (mm)

SHV 200

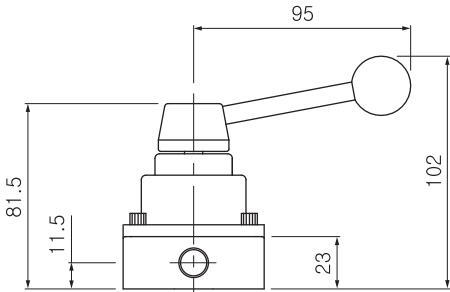
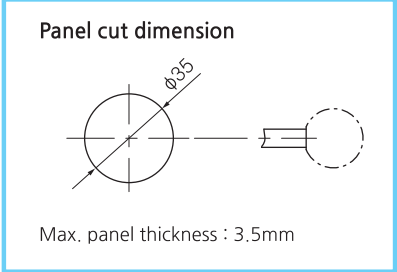
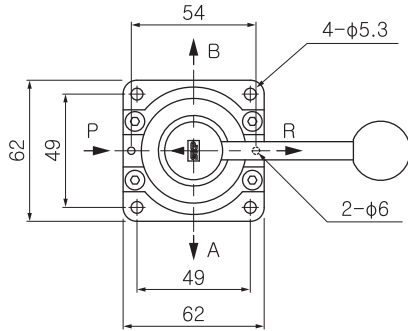

SHV 300

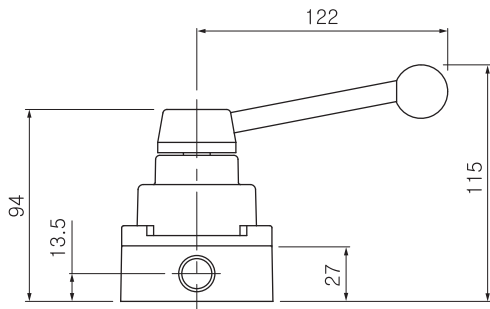
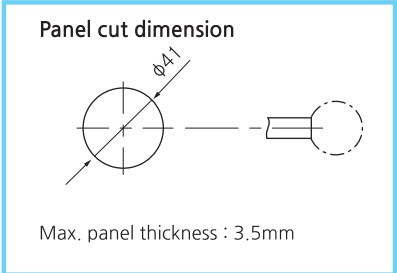
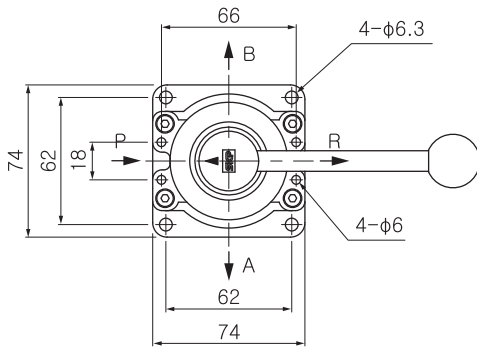

DIMENSIONS (mm)

SHV 400-04

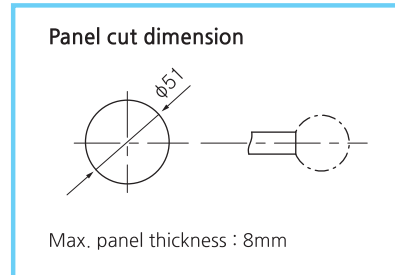
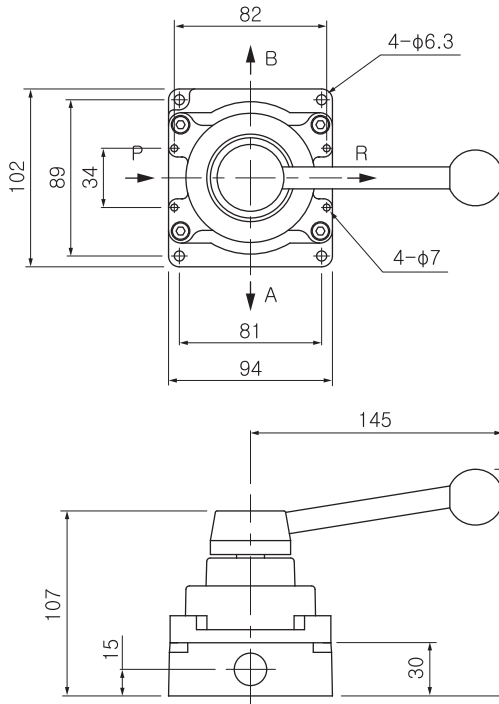

SHV 400-06

